

INSTALLER GUIDE

Model 719

(GC No. 32-032-53)

INSET LIVE FUEL EFFECT GAS FIRE
INCORPORATING THE

VALOR **FireSlide** CONTROL
with

Ultimate or

CE **Colourway** Firefront

**THIS APPLIANCE IS FOR USE WITH NATURAL GAS (G20)
WHEN CONVERTED USING CONVERSION KIT NO. 0595221 THIS
APPLIANCE IS FOR USE WITH PROPANE GAS (G31)
THIS APPLIANCE IS SUITABLE ONLY FOR INSTALLATION IN THE UNITED
KINGDOM (GB) AND THE REPUBLIC OF IRELAND (IE).**

We trust that these instructions give sufficient details to enable this appliance to be installed and maintained satisfactorily. However, if further information is required, our

Valor Technical Helpline will be pleased to help.

Telephone **08706 061 065** (National call rates apply in the United Kingdom)

In the Republic of Ireland call 0044 08706 061 065

INSTALLER: Please leave this guide with the owner

INSTALLER GUIDE

Safety First.

Valor fires are CE Approved and designed to meet the appropriate British Standards and Safety Marks.



Quality and Excellence.

At the heart of every Valor fire.

All Valor fires are manufactured to the highest standards of quality and excellence and are manufactured under a BS EN ISO 9001 quality system accepted by the British Standards Institute.



The Highest Standards

Valor is a member of the Society of British Gas Industries which works to ensure high standards of safety, quality and performance.



Careful Installation

Valor is a CORGI registered company. All our gas fires must be installed by a competent CORGI Registered Installer in accordance with our Installer Guide and should not be fitted directly on to a carpet or floor of combustible material.



Valor Heating, Erdington, Birmingham B24 9QP

www.valor.co.uk

Because our policy is one of constant development and improvement, details may vary slightly from those given in this publication

INSTALLER GUIDE

CONTENTS

<u>Section</u>	<u>Heading</u>	<u>Page</u>
1.	SAFETY	4
2.	APPLIANCE DATA	5
3.	GENERAL INSTALLATION REQUIREMENTS	6
4.	PACK CONTENTS	12
5.	FIREPLACE CHECK	14
6.	IGNITION CHECK	15
7.	GAS SUPPLY CONNECTION	16
8.	PREPARING APPLIANCE FOR INSTALLATION	17
9.	CONVECTION BOX INSTALLATION	19
9.1	Method 1- Front Fixing to Fireplace Surround	19
9.2	Method 2 - Cable Retention	20
9.3	Floor Sealing (All installations)	22
10.	BURNER & SUPPLY PIPE INSTALLATION	22
11.	FITTING THE FRONT SURROUND	23
12.	CERAMIC COALS INSTALLATION	24
13.	FIREFRONT CASTING8INSTALLATION	26
14.	FULL OPERATING CHECKS	26
15.	SPILLAGE & FLAME SUPERVISION CHECKS	27
15.1	Check for Spillage	27
15.2	Flame Supervision & Spillage Monitoring System	28
16.	FINAL REVIEW	29
17.	SERVICING & PARTS REPLACEMENT	30
17.1	Checking the aeration setting of the burner.	30
17.2	To Remove the Ignition Microswitch	31
17.3	To Remove the Gas Shut-Off Microswitch	31
17.4	To Remove the Fire Front Surround	32
17.5	To Replace the Control Slide Button	32
17.6	To Remove the Burner Unit	32
17.7	To Remove the Electronic Ignition Generator	33
17.8	To Remove the Thermocouple Interrupter Block	33
17.9	To Remove the Pilot Unit	34
17.10	To Remove the Shut-Off Tap	34
17.11	To Remove the Gas Flow Rate Controller	35
17.12	To Replace the Burner	36
17.13	To Remove the Main Burner Injector	36
17.14	To Remove the Appliance from the Fireplace	36
18.	SHORT LIST OF SPARES	38

INSTALLER GUIDE

1. SAFETY

Installer

Before continuing any further with the installation of this appliance please read the following guide to manual handling

- The lifting weight of this appliance with the surround removed is 8.4 kg.
- One person should be sufficient to lift the fire. If for any reason this weight is considered too heavy then obtain assistance.
- When lifting always keep your back straight. Bend your legs and not your back.
- Avoid twisting at the waist. It is better to reposition your feet.
- Avoid upper body/top heavy bending. Do not lean forward or sideways whilst handling the fire.
- Always grip with the palm of the hand. Do not use the tips of fingers for support.
- Always keep the fire as close to the body as possible. This will minimise the cantilever action.
- Use gloves to provide additional grip.
- Always use assistance if required.

INSTALLER GUIDE

2. APPLIANCE DATA

This product uses fuel effect pieces and a burner compartment rear wall containing Refractory Ceramic Fibres (RCF), which are man-made vitreous silicate fibres. Excessive exposure to these materials may cause irritation to eyes, skin and respiratory tract. Consequently, it is important to take care when handling these articles to ensure that the release of dust is kept to a minimum. To ensure that the release of fibres from these RCF articles is kept to a minimum, during installation and servicing we recommend that you use a HEPA filtered vacuum to remove any dust and soot accumulated in and around the fire before and after working on the fire. When replacing these articles we recommend that the replaced items are not broken up, but are sealed within a heavy duty polythene bag, clearly labelled as RCF waste. This is not classified as “hazardous waste” and may be disposed of at a tipping site licensed for the disposal of industrial waste. Protective clothing is not required when handling these articles, but we recommend you follow the normal hygiene rules of not smoking, eating or drinking in the work area and always wash your hands before eating or drinking. This appliance does not contain any component manufactured from asbestos or asbestos related products.

Gas	Natural (G20)	Propane (G31) *
Inlet Pressure	20mbar	37mbar
Input - Max. (Gross)	6.0kW (20,500Btu/h)	6.1kW (20,800Btu/h)
Input - Min. (Gross)	2.7kW (9,212Btu/h)	4.3kW (14,670Btu/h)
Inlet Test Pressure (Cold)	20.0 ± 1.0mbar (8.0 ± 0.4in w.g.)	37.0 ± 1.0 mbar (14.85 ± 0.4in w.g.)
Gas Connection	8mm pipe	8mm pipe
Burner Injector	Stereomatic Cat 82 - 069	Stereomatic Size 128
Pilot & Atmosphere Sensing Device	Copreci Ref. O.D.S 21500/166	Copreci Ref. O.D.S 21500/166 Fitted with RBM 180 - 02 injector
Ignition	Electronic (Battery 9V PP3)	Electronic (Battery 9V PP3)
Aeration	See section 17.1	Non-adjustable

* When converted using Kit 0595221

The appliance data label is located on a plate at the base of the fire. This can be seen by removing the lower frefront casting.

INSTALLER GUIDE

Where no specific instructions are given, reference should be made to the relevant British Standard Code of Practice.

3.2 In the United Kingdom, as supplied, this appliance can be installed in the following situations: -

3.2.1 A masonry chimney with a minimum diameter of 175mm (7") free from any obstruction, and with any damper or restrictor plate in the chimney removed or secured, and having a minimum effective flue height of 3m (10ft). A masonry chimney having a correctly installed flue liner to BS715 and with a minimum flue diameter of 125mm is also acceptable. Chair brick removal may not be required providing at least 50mm clearance is available from the flue outlet to any fireplace component.

3.2.1.1 'Hole-in-the-wall' Installations

- **It is recommended that a hearth should be installed as in figure 1.**
- **If a hearth is not fitted, the fire must be installed so that the distance from the base of the fireplace opening in the wall to the finished floor level is at least 72mm.**

3.2.2 To a fireplace incorporating a metal flue box conforming to BS715 with a minimum internal depth of 195mm. Incombustible mineral wool insulation of not less than 100mm thickness must be applied to the top surface of the firebox (See figure 2) and it must stand on a non-combustible hearth. See figure 1.

3.2.3 To a fireplace that has a precast concrete or clay flue block system conforming to BS1289 or BS EN 1806. The appliance is suitable for installations conforming to older versions of BS1289 as well as the current edition. The flue blocks must have a minimum width not less than 63mm and a cross-sectional area not less than $13,000\text{mm}^2$. Older editions of BS1289 required a cross-sectional area of $13,000\text{mm}^2$. The current revision of the standard requires $16,500\text{mm}^2$. This appliance is suitable in both cases. The total depth of the opening measured from the finished front of the fireplace (Including plaster, surround etc.)

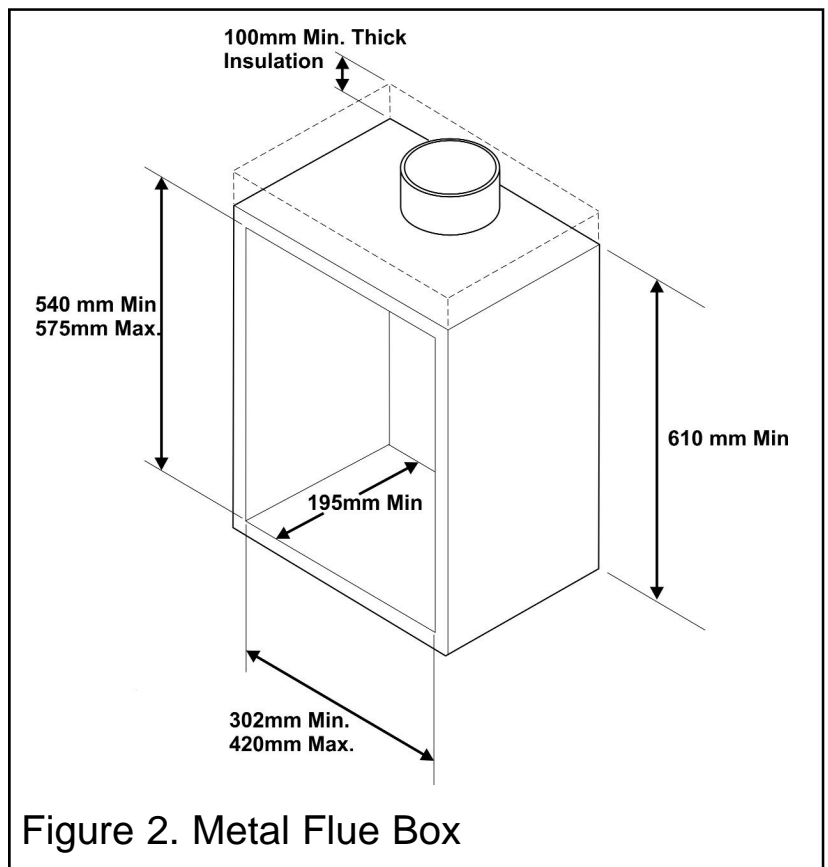

INSTALLER GUIDE

must be *not less than the dimension shown in figure 3.*

The current versions of BS1289 and BS EN 1806 recommend that there should be an air space or insulation between the flue blocks and the plaster because heat transfer may cause cracking on directly plastered flues. However, generally this appliance is suitable for installations under all circumstances unless there is a history of cracking problems. Remember that faults such as cracking may be caused by poorly built and restrictive flues, e.g. mortar extrusions, too many bends, flue heights below three metres, restrictive terminations, etc.

3.2.4 If the fireplace opening is greater than the acceptable dimensions given in this guide, do not use the back of a fire surround or marble to reduce the opening. This may cause cracking of the surround back or marble.

3.3 The following flues are suitable:

- 225mm x 225mm conventional brick flue. If a flue liner is used, it must be a minimum of 125mm diameter. The liner must be sealed to the surrounding area above the fireplace opening and to the top of the chimney. An approved terminal must be fitted.
- 200mm diameter factory made insulated flue manufactured to BS 4543.

- A properly constructed precast flue conforming to B.S 1289 or BS EN 1806.
- A flue pipe with a minimum diameter of 175mm. See B.S 6461 Part 1 for suitable materials. Metal flue pipes must comply with B.S 715.
- Single wall, twin wall or flexible flue liner of minimum diameter 125mm. The materials used are stainless steel or aluminium as specified in B.S. 715.

3.3.1 The minimum effective height of the flue must be 3m.

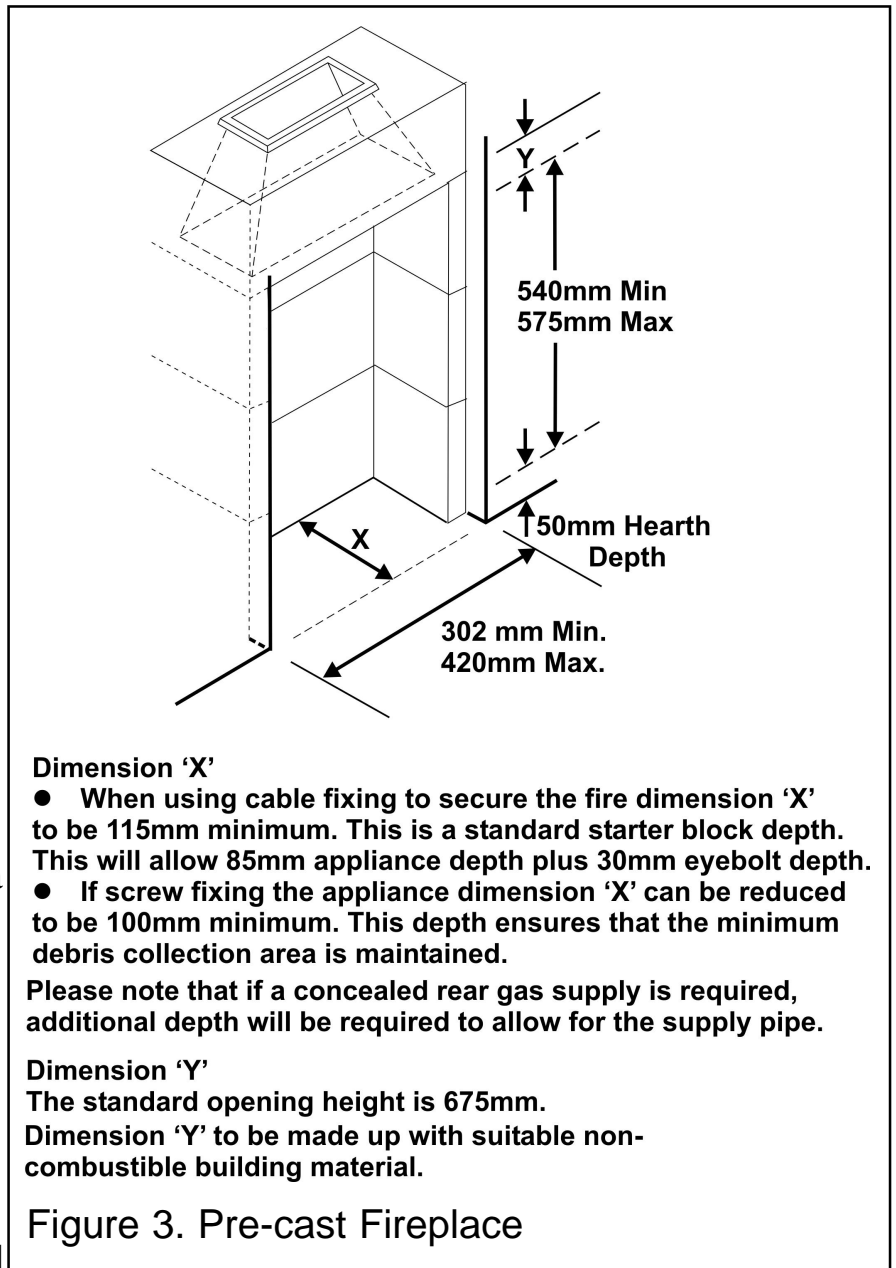

INSTALLER GUIDE

3.3.2 The flue must be clear of any obstruction and its base must be clear of debris.

3.3.3 The flue must be completely sealed so that combustion products do not come into contact with combustible materials outside the chimney.

3.3.4 The flue must serve only one fireplace.

3.4 The flue must conform to BS 5440: Part 1 in design and installation.

The flue, measured from the bottom of the fireplace opening to the bottom of the terminal, shall be not less than 3m in actual vertical height. When calculated in accordance with BS 5440: Part 1 Annex A, the minimum **equivalent** height of the flue shall be 2.0m of 125mm dia. flue pipe.

3.5 The flue must not be used for any other appliance or application.

3.6 Any chimney dampers or restrictors should be removed. If removal is not possible they must be fixed in the open position.

3.7 If the appliance is intended to be installed to a chimney, which was previously used for solid fuel, the flue must be swept clean prior to installation. All flues should be inspected for soundness and freedom from blockages.

3.8 If the fireplace opening is an underfloor draught type, it must be sealed to stop any draughts.

3.9 The appliance must be mounted behind a non-combustible hearth (N.B. conglomerate marble hearths are considered as non-combustible). The appliance can be fitted to a purpose made proprietary class “O”-150°C surround. The hearth material must be at least 12mm thick. The periphery of the hearth (or fender) should be at least 50mm above floor level to discourage the placing of carpets or rugs over it. The appliance must not stand on combustible materials or carpets (See figure 1).

3.10 The front face of the fireplace should be reasonably flat over the area covered by the convector box top and side flange seals to ensure good sealing. These faces should be made good if necessary. The fireplace floor should be reasonably flat to ensure that a good seal with the convector box can be made.

INSTALLER GUIDE

3.11 The minimum height from the top surface of the hearth to the underside of any shelf made from wood or other combustible materials is detailed below.

- For a shelf up to 150mm deep: Minimum height = 750mm.
- For a shelf deeper than 150mm: 150mm + 12.5mm for every 25mm depth over 150mm. (See Graph 1)

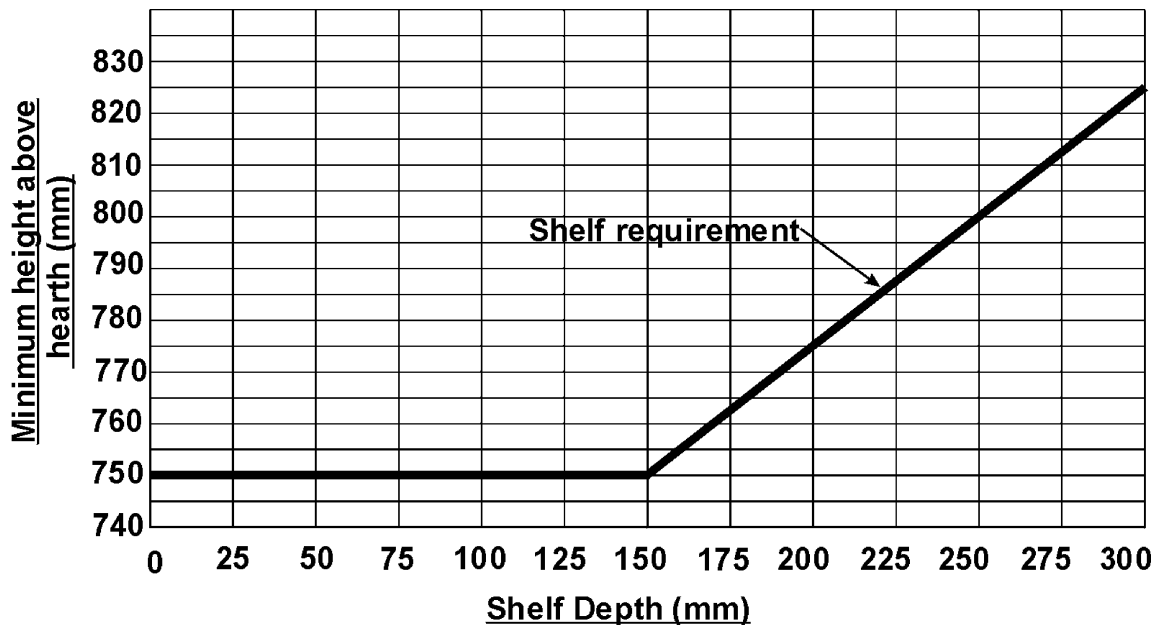

Graph 1. Combustible shelf clearances

3.12 Note that soft wall coverings (e.g. embossed vinyl, etc.) are easily affected by heat. They may scorch or become discoloured when close to a heating appliance. Please bear this in mind when installing.

3.13 The appliance must not be installed in any room, which contains a bath, or shower or where steam is regularly present.

3.14 An extractor fan may only be used in the same room as this appliance, or in any area from which ventilation for the appliance is taken, if it does not affect the safe performance of the appliance. Note the spillage test requirements detailed further on in this manual. If the fan is likely to affect the appliance, the appliance must not be installed unless the fan is permanently disconnected.

3.15 Normal adventitious ventilation is usually sufficient to satisfy the ventilation requirements of this appliance. In GB reference should be made to BS 5871 Part 2 and in IE reference should be made to the current edition of IS 813 “Domestic gas Installations” which makes clear the conditions that must be met to demonstrate that sufficient ventilation is available

INSTALLER GUIDE

3.16 Propane gas appliances must not be installed in a room, which is built entirely below ground level (See BS 5871 Pt2).

3.17 If the appliance is to be fitted against a wall with combustible cladding, the cladding must be removed from the area covered by the outer surround. The cladding must also not touch the surround. (See figure 4). We suggest that the actual surround is used as a template to mark the area for combustible cladding removal and that this area is increased by at least 2mm all round.

3.18 The minimum allowable distance from the outside of the appliance case to a corner wall having combustible material or any other combustible surface which projects beyond the front of the appliance is shown in figure 5. For access purposes the recommended clearances to non combustible surfaces are shown in figure 5.

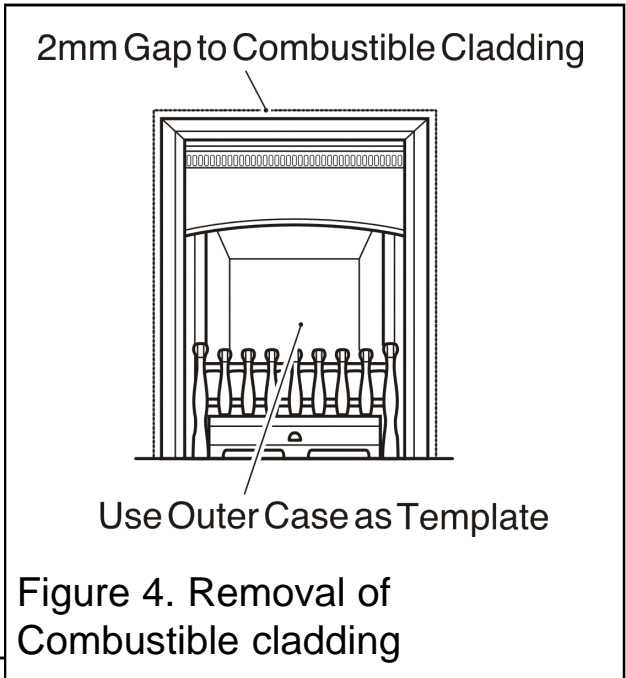

The minimum mandatory clearance to combustible surfaces projecting beyond front of appliance is 178mm for the Ultimate model and 150mm for the Colourway model. For access purposes a 50mm clearance is recommended to non-combustible surfaces.

The minimum mandatory clearance to combustible surfaces projecting beyond front of appliance is 178mm for the Ultimate model and 150mm for the Colourway model. For access purposes a 100mm clearance is recommended to non-combustible surfaces.

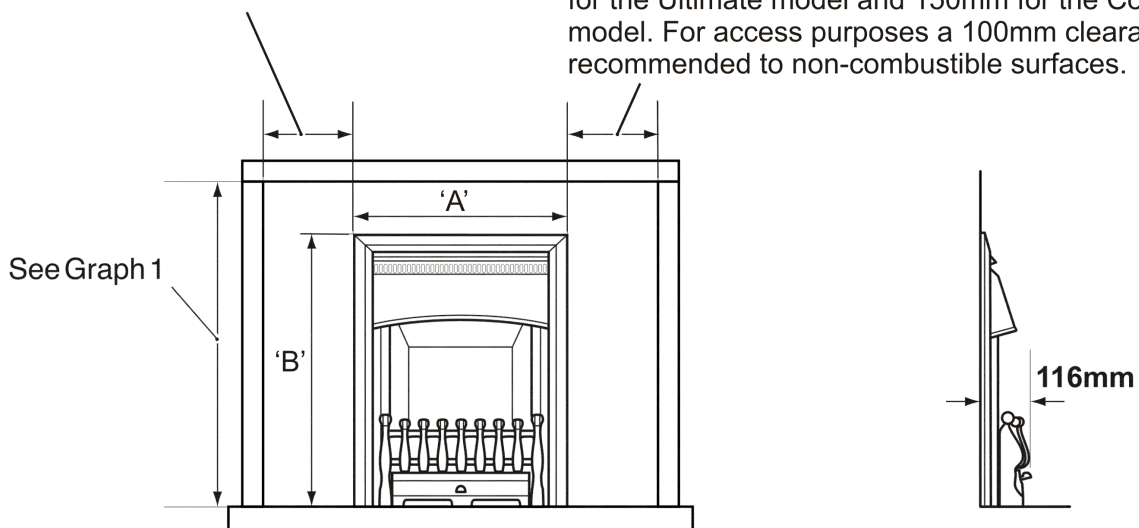

Model	Dimension 'A' (mm)	Dimension 'B' (mm)
Ultimate	470	600
Colourway	513	622

Figure 5. Appliance dimensions

INSTALLER GUIDE

3.19 Proprietary terminals must comply with BS 715 or BS 1289. Any terminal or termination must be positioned in accordance with BS 5440 Part 1 to ensure that the products of combustion can be safely dispersed into the outside atmosphere. Where the appliance is connected to an unlined brick chimney it is generally unnecessary for the chimney pot to be replaced or for a terminal to be fitted unless the flue has a diameter smaller than 170mm.

3.20 The appliance is fitted with an A.S.D (Atmosphere sensing device). If the appliance closes down after a period of operation for no apparent reason, the consumer should be informed to stop using the appliance until the installation and appliance have been thoroughly checked. The A.S.D will shut the appliance down if an unacceptable amount of harmful products of combustion accumulate. Under no circumstances should the A.S.D be altered or bypassed in any way. Only a genuine manufacturers replacement part should be fitted. The individual A.S.D components are not replaceable.

3.21 A fireguard complying with BS 8423 should be fitted for the protection of young children, the elderly, or the infirm.

4. PACK CONTENTS

The items required for this appliance are packed in two sections.

Section 1 - Fire unit contains:

- 1 Convection box and burner unit
- 1 Loose parts pack including: -
 - 1 Nut and Olive for 8mm Inlet Pipe
 - 1 Front base coal
 - 1 Rear base coal
 - 1 Pack of loose ceramics
- 2 Small 'U' seals for convection box side flanges
- 1 Strip of Floor Sealing Tape
- 1 Flue restrictor with 2 securing screws
- 6 Fibre Plugs
- 4 Woodscrews
- 2 Tension Cables
- 2 Cable Adjusters
- 4 Eyebolts
- 1 Installation template
- 1 Smoke match tube

INSTALLER GUIDE

- 1 Length of Self-Adhesive Foam seal
- 1 Battery
- 1 Slider knob extension bracket for Colourway
- 4 Screws for knob extension bracket for Colourway
- 1 "T" connector including pressure test point
- 1 Literature Pack

Section 2 -

Fire front casting contains

- 1 Firefront casting
- 1 Front cover casting.

Section 3 -

Firefront surround contains

- 1 Firefront surround
- 1 Upper case support
- 3 Screws for upper case support
- 2 Lower case support brackets
- 4 Screws for case fixing brackets
- 2 Machine screws for front surround fixing.

Remove all the items carefully to prevent damage. Take special care when handling the ceramic components. Some items may be contained in the packaging fitments - Examine the packaging carefully before discarding. Check that all the items are present and undamaged.

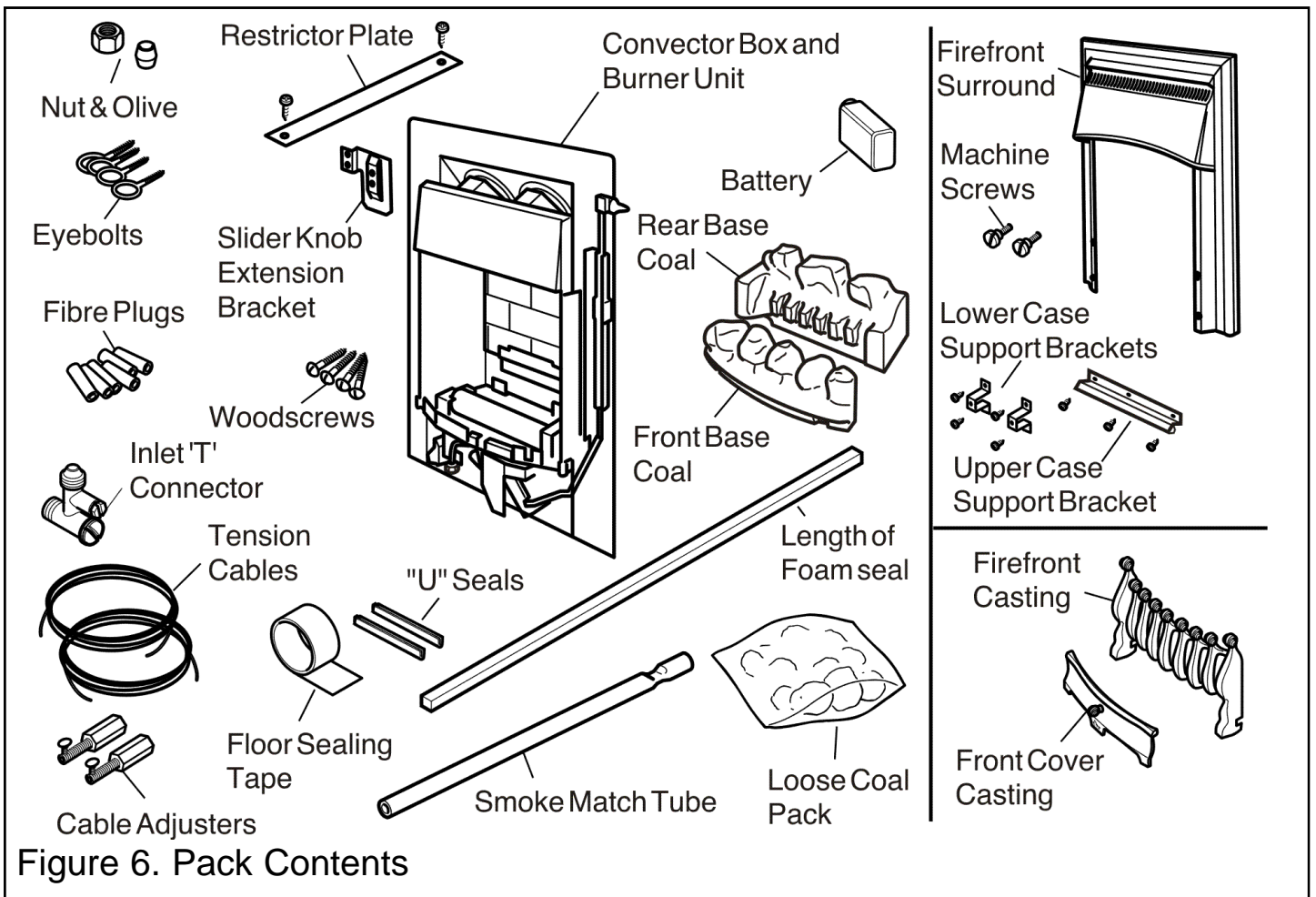

INSTALLER GUIDE

5. FIREPLACE CHECK

5.1 Fireplace check

5.1.1 Fireplace size

The fireplace must comply with the requirements described in section 3.2. This may entail removing the fireback and infill material behind the fireback.

5.1.2 Fireplace general condition

The fireplace floor should be reasonably flat to ensure that the convector box can be installed without it rocking and so that a good seal can be made at the bottom front of the box. The front face of the fireplace should be reasonably flat over the area covered by the convector box top and side flange seals to ensure good sealing. These faces should be made good if necessary. If the appliance is to be fitted against a wall with combustible cladding, the cladding must be removed from the area covered by the outer surround. The cladding must also not touch the surround. (See figure 4). We suggest that the actual surround is used as a template to mark the area for combustible cladding removal and that this area is increased by at least 2mm all round.

5.1.3 Soundness for appliance attachment

Two primary methods of retaining the appliance are provided: -

- 1) By fixing to the fireplace front surround.
- 2) Using concealed tension cables fixed to the rear of the fireplace opening together with secondary fixing to the fireplace floor.

The methods are detailed in section 9 of this manual. Before selecting the retention method, consult with the customer. Method 2 is provided for instances where drilling holes in the front surface of the fireplace surround is unacceptable to the customer or otherwise impractical. *N.B. It is unwise to attempt to drill into marble without the proper tools and equipment.*

If method 1 is chosen, make sure that the front surround area is sound enough to take the rawlplugs and woodscrews. If necessary, make sound with a suitable cement.

If method 2 is chosen, make sure that the areas at the back and towards the centre of the fireplace floor are sound enough to take the eyebolts and screws. If these areas have deteriorated due to prolonged use, they should be made sound with a suitable cement.

5.1.4 Installations using a metal flue box

The whole of the top surface of the metal flue box must be covered with a minimum 100mm layer of mineral wool or equivalent insulation. (See figure 2).

5.2 Fireplace Flue Pull

Close all doors and windows in the room in which the appliance is to be installed. After confirming with a match that smoke is drawn into the flue, light a 13 gram smoke pellet and check that there is a definite flow through the flue. Verify outside that the smoke exits from one terminal only and that the termination is suitable. Observe where

INSTALLER GUIDE

possible, upstairs rooms and loft spaces for signs of escaping smoke indicating a defective flue. If there is not a definite flow warm the flue for a few minutes and repeat the smoke pellet test. If there is still no definite flow the flue may need remedial work – **Do not fit the appliance until there is a definite flow through the flue.**

6. IGNITION CHECK

Before attempting to install, it is worth checking that the electronic ignition system performs satisfactorily.

Fit the battery to the ignition block located below the burner tray at the left side (see figure 7). The positive terminal (+) is to the top as you insert.

- Depress the slider control as far as it will go. This should close the ignition circuit. Sparks should be seen tracking from the electrode pin to the pilot tip. See figure 8.
- If there are no sparks make the following checks.
- Check condition of battery and that it is correctly fitted.
- If the above is satisfactory, check the ignition circuit and components - see the servicing section in this manual.

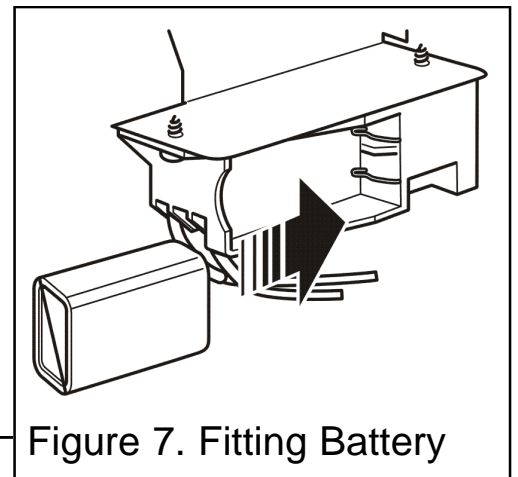

Figure 7. Fitting Battery

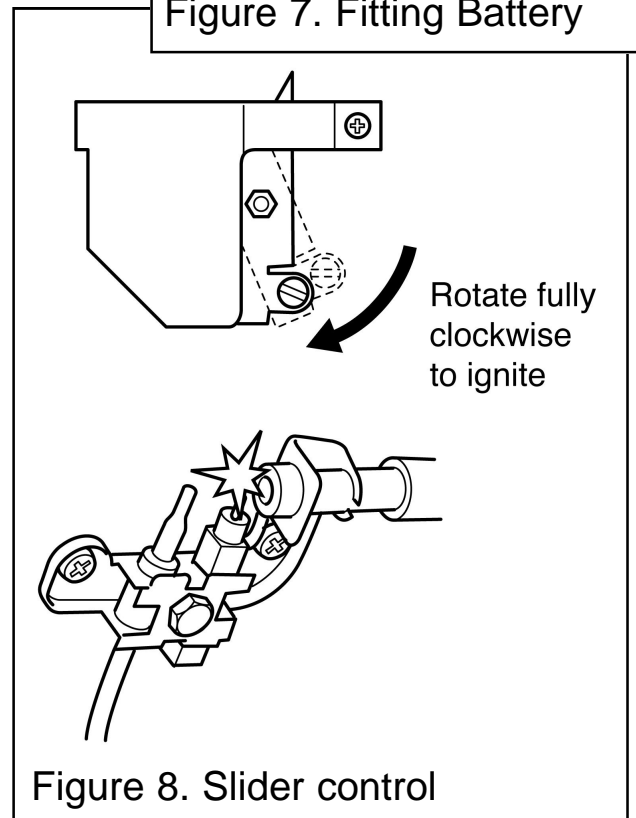

Figure 8. Slider control

INSTALLER GUIDE

7. GAS SUPPLY CONNECTION

A nut and olive are provided for an 8mm pipe inlet connection to the 'T' connector at the bottom front of the appliance. The 'T' connector can be rotated to allow a connection from any direction. The 'T' connector includes a valve for isolating the gas supply and a pressure test point. The 'T' connector should be fitted to the supply pipe at this stage. The supply pipe must be rigid material. Flexible pipe must not be used.

7.1 Concealed Supply Pipe Connection

If a concealed connection from inside the fireplace is required then, **before the appliance is fitted into the fireplace** it will be necessary to extend the supply line so that it will project through the sealed opening at the back of the convection box (near the left side) and run to the 'T' Connector at the front

The pipe run from the supply line up to the rear opening in the convection box must be kept clear of the area which will be taken by the convection box when it is installed. A template is supplied to aid the installation of the pipe run.

We recommend the following method for installing with a concealed supply pipe:

1. Cut the template to the shape shown by the "Debris catchment area". Note that the areas are different for fireplaces with conventional brick flues and precast flues.
2. Place the template on the fireplace floor (printed side upward) with the front line level with the front surface of the fireplace. The centre line of the template should line up with the centre of the fireplace. Tape the template securely in this position.
3. Make sure that the fireplace is clear of all material over the full area covered by the template including that marked "Debris catchment area".
4. Install the supply pipe to run through the thick line marked "Supply pipe entry" and up to the inlet 'T' connector position. Note that the centre of the appliance inlet 'T' connector is 30mm above the fireplace floor. The inlet elbow should be removed from the appliance and fitted to the supply pipe at this stage. Remove the template. **Note: If the supply pipe connection is to be from the right side, keep the template, It will be useful for bending the pipe later on (See section 9).**

7.2 Side Supply Pipe Connection

The appliance is designed to allow a side supply pipe to run in front of the front surround and through a cut- out at either rear bottom corner of the fire front casting. For side connection, final installation of the supply pipe should be left until the appliance is installed in the fireplace. For a right side connection the pipe will have to be formed to clear the burner unit mechanism.

INSTALLER GUIDE

8. PREPARING APPLIANCE FOR INSTALLATION

8.1 Appliance Preparation

1. Remove any transit tape and packing and inspect for any evidence of mishandling which might affect the performance. Each unit is flame tested before it leaves the factory and as a result there may be slight discolouration around the burner ports.

2. Disconnect the control linkage from the burner unit by removing the shouldered screw which joins the control linking bar to the control pivot unit. See figure 9.

3. Detach the burner unit from the convector box by removing two screws - See figure 10. Lift the burner unit clear.

4. Fit the two small 'U' section seals to the bottom edges of the convection box side flanges (See figure 11).

5. Fit the two lower case support brackets to the convection box side flanges. See figure 12.

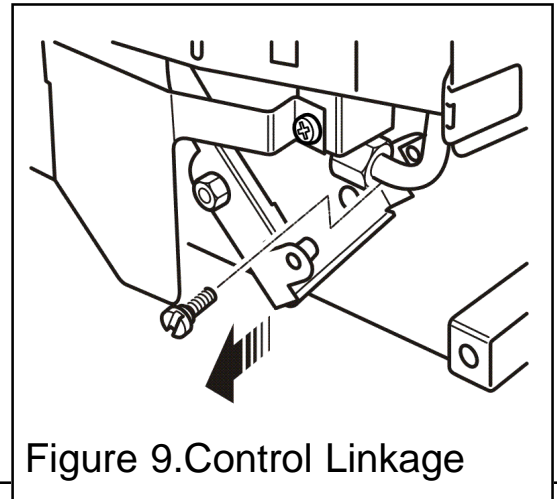

Figure 9. Control Linkage

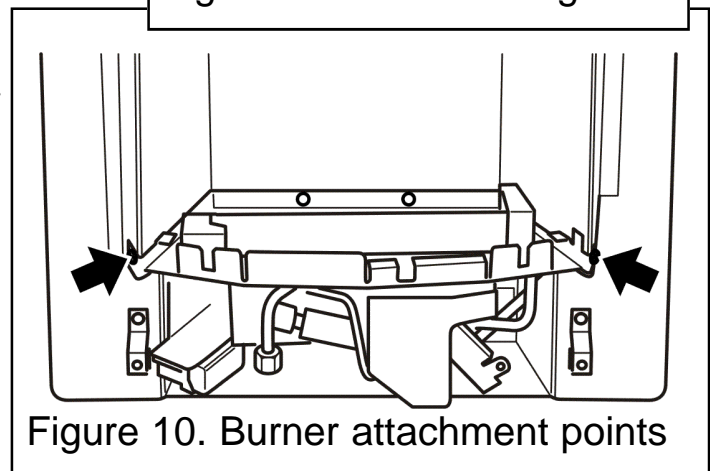

Figure 10. Burner attachment points

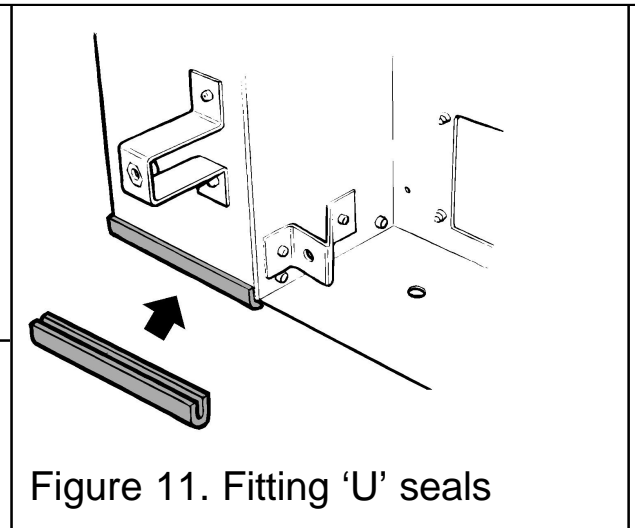

Figure 11. Fitting 'U' seals

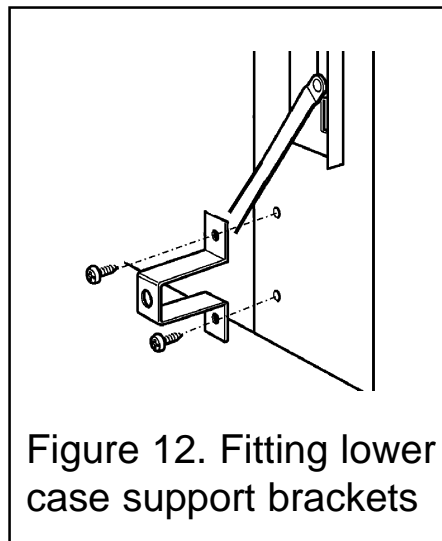

Figure 12. Fitting lower case support brackets

INSTALLER GUIDE

6. For concealed connection only: Pierce a hole in the seal at the back of the convection box. See figure 13. The seal must envelop the pipe. If the hole is larger than the pipe, seal it with tape. Do not pierce the seal unless the supply pipe is to pass through it.

7. Fit the upper case support strip to the top of the convection box, using three screws inserted from the back of the appliance. See figure 14.

8. Colourway only

Detach the slider knob by removing and discarding two screws. Attach the slider knob extension bracket to the slider arm using two of the screws supplied in the bag containing the extension bracket. Attach the slider knob to the slider extension bracket using the other two screws supplied in the bag containing the extension bracket. See figure 15.

9. There is a length of self adhesive foam seal supplied with the fire. This will need to be fitted to the outer rear edges of the side and top flanges of the convector box. Cut the foam seal to the required length. Be careful not to stretch the seal when measuring. Remove the protective backing from the foam seal and fit this to the rear of the top flange (See figure 16).

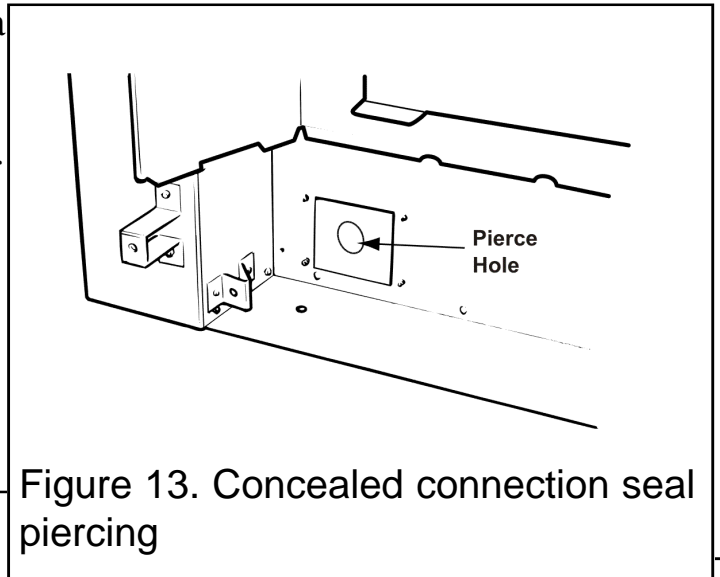

Figure 13. Concealed connection seal piercing

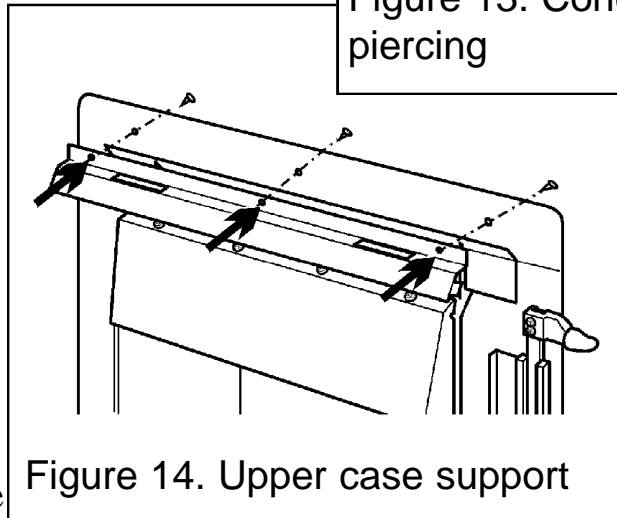

Figure 14. Upper case support

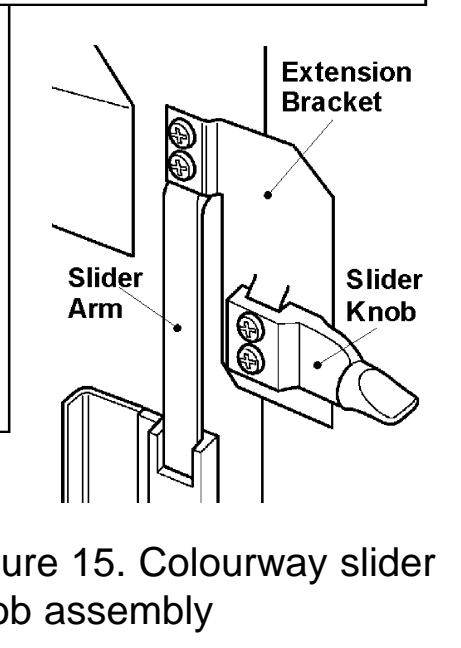

Figure 15. Colourway slider knob assembly

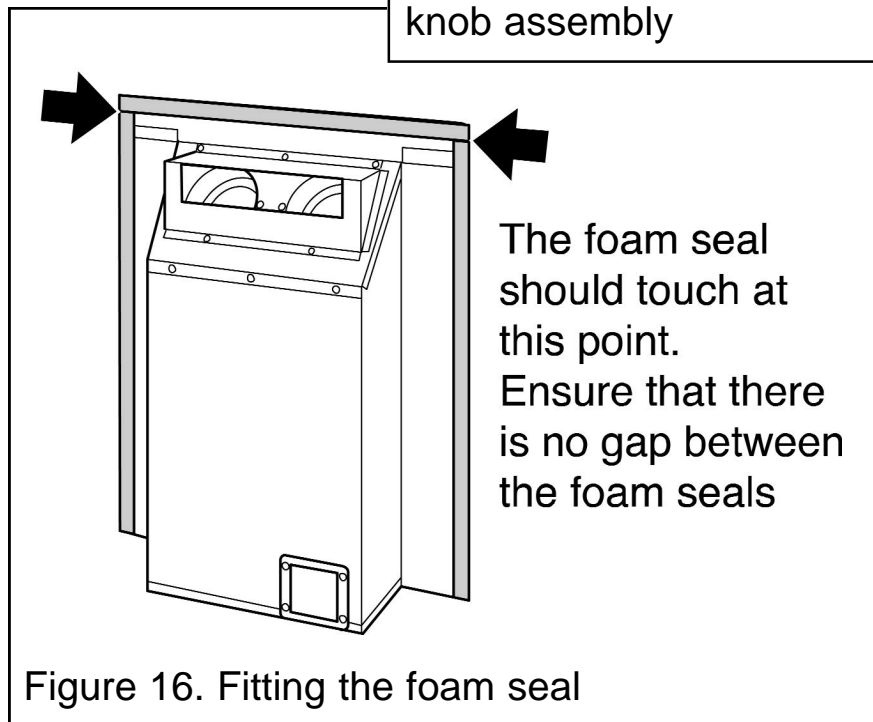

Figure 16. Fitting the foam seal

INSTALLER GUIDE

8.2 The Flue Restrictor

This appliance is supplied with a flue restrictor for use where the flue draught is excessive. **The restrictor must not be fitted where a precast flue or a 125mm flue liner is used.** For flue liners greater than 125mm and all other installations the restrictor should be fitted. There may however, be certain exceptional circumstances where fitting the restrictor causes the fire to fail the spillage test. In such cases the restrictor will have to be removed. After removal conduct the spillage check again.

Fit the restrictor as shown in figure 17 using the two screws provided.

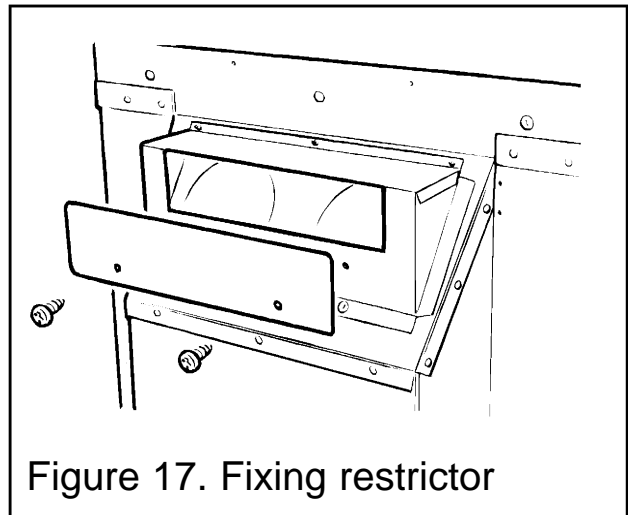

9. CONVECTION BOX INSTALLATION

9.1 Method 1- Front Fixing to Fireplace Surround

1. Make sure that the fireplace front surround area is sound enough to take the rawlplugs and woodscrews. If necessary, make sound with a suitable cement.

2. Place the convector box centrally in the fireplace in the position in which it is to be permanently installed. If a concealed connection is being used, insert the convector box into the fireplace feeding the supply pipe through the pierced hole in the rear seal.

3. Mark the fireplace front surround through the four fixing holes in the side flanges of the convector box. See figure 18.

4. Remove the convector box. Drill four holes in the fireplace front surround at the marked positions using a no.12 masonry drill.

5. Insert a rawlplug into each hole.

6. Place the convector box back in position in the fireplace.

7. Fit a woodscrew through each hole in the convector box flanges and tighten to seal the box to the fireplace surround.

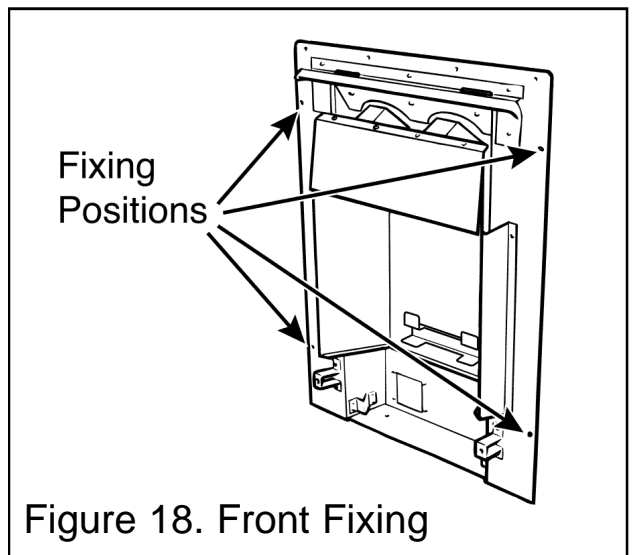

INSTALLER GUIDE

9.2 Method 2 - Cable Retention

1. Make sure that the relevant areas at the fireplace back are sound enough to take the eyebolts. If these areas have deteriorated due to prolonged use they should be made sound with a suitable cement.

2. Drill four holes in the rear wall of the fireplace for the eyebolt plugs. The holes should be drilled within the range of positions shown in figure 19 using a no.12 masonry drill. The holes

should be equidistant each side of the centre line of the fireplace to ensure that the appliance finishes centrally in the opening when tension is applied to the cables.

3. Insert a fibre plug into each hole. Use the fibre plugs supplied with this appliance - **Never use plastic plugs instead of the fibre plugs supplied.** Screw the eyebolts into the plugs. Make sure that the bolts are secure.

4. Place the convector box unit close to the fireplace but allow sufficient access into the fireplace opening so that the cables can be threaded through the eyebolts and returned through the back of the convector box. If a concealed connection is being used, insert the convector box into the fireplace feeding the supply pipe through the pierced hole in the rear seal.

5. The convection box has two holes at each side of the convected air opening. Insert one end of each cable (one cable each side) from the back through the lower of the two holes and return the end through the upper of the holes. See figure 20. Give the cables a pull so that they grip against the convection box flanges.

6. Thread the cables through the upper eyebolts in the rear wall and then through the lower eyebolts. Return the cables through the holes near the bottom of the convection box back panel and through the "V" shaped brackets near the

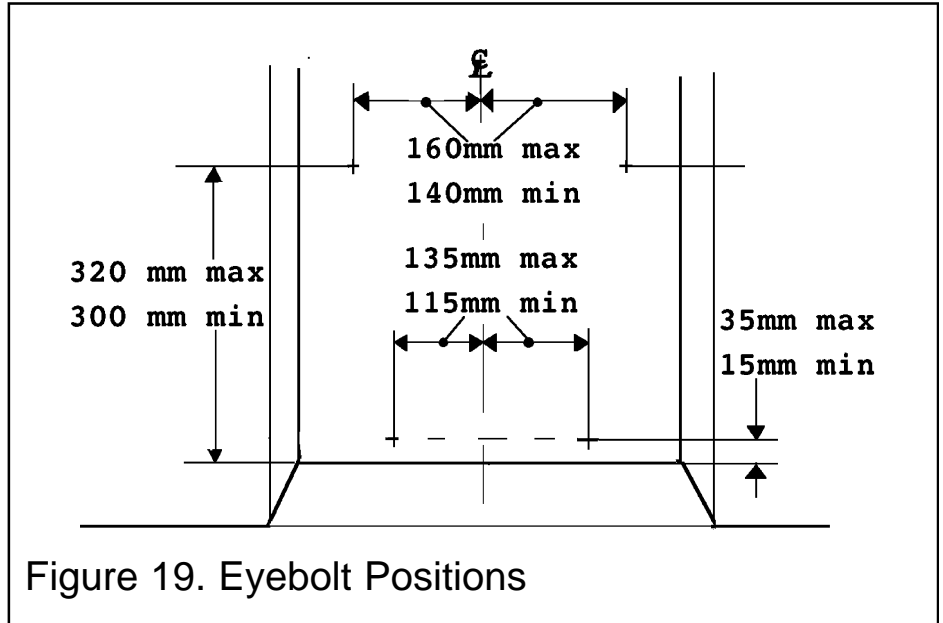

Figure 19. Eyebolt Positions

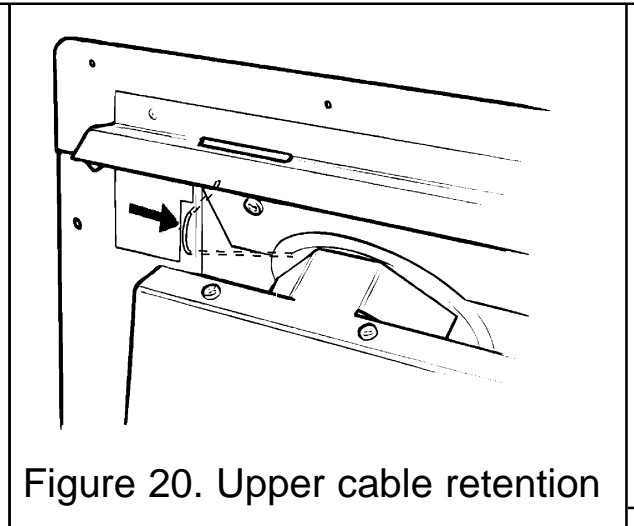

Figure 20. Upper cable retention

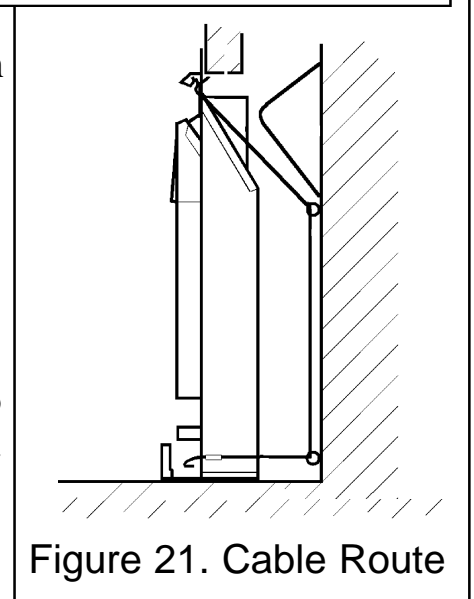

Figure 21. Cable Route

INSTALLER GUIDE

bottom front sides of the convection box. See figure 21.

7. Place the convection box fully back into the fireplace opening so that it is sealed against the fireplace front surround.

8. Fit a cable retainer over the bottom end of each cable.

9. Pull each cable taut. Push the cable retainers hard up against the "V" brackets. Tighten the screws in the retainers so that they clamp the cables in position. Apply tension to the cables by turning the hexagonal adjusters by hand. See figure 22.

10. Drill a hole into the fireplace floor through each of the two holes in the base of the convection box using a no.12 masonry drill. See figure 23.

11. Insert a fibre plug into each hole. Use the rawlplugs supplied with this appliance - Never use plastic plugs instead of the fibre plugs supplied. Fit a woodscrew in each plug and tighten.

12. Inspect the installation of the convection box against the fireplace surround. If the convection box is aligned squarely and the sealing is satisfactory, fully tighten the cable retainers.

13. If the convection box is not correctly aligned, release the tension on the cables by slackening the screws and turning the hexagonal adjusters fully anticlockwise. The convection box should then automatically realign itself. Pull each cable taut again and push the cable retainers back against the "V" brackets. Again, tighten the screws in the retainers and apply tension to the cables by turning the hexagonal adjusters clockwise as far as possible.

14. Push the free length of the cables inside the convection box so that they are available to allow easy removal and refitting of the appliance during subsequent service calls.

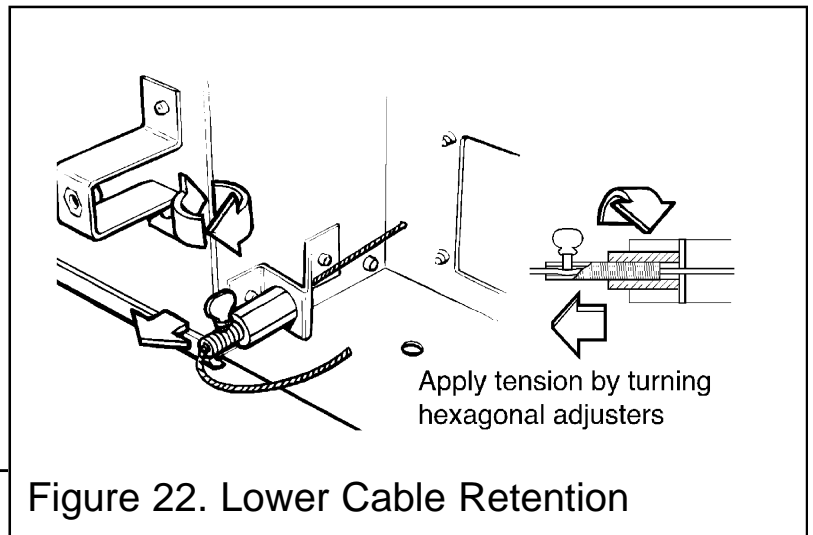

Figure 22. Lower Cable Retention

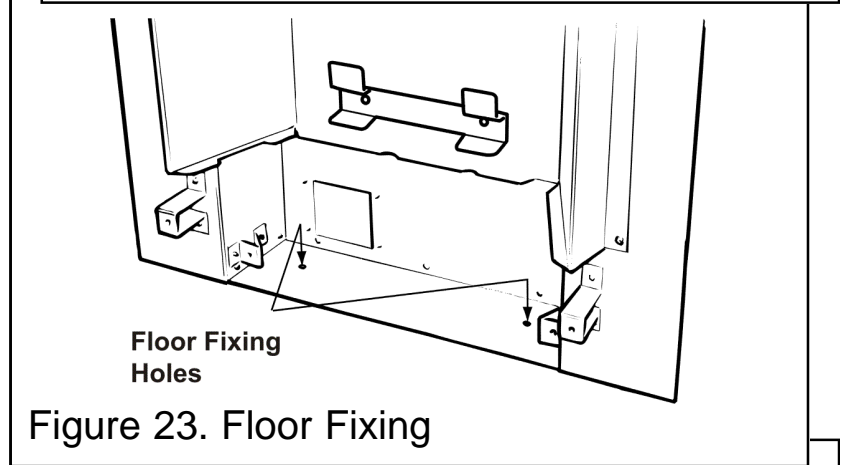

Figure 23. Floor Fixing

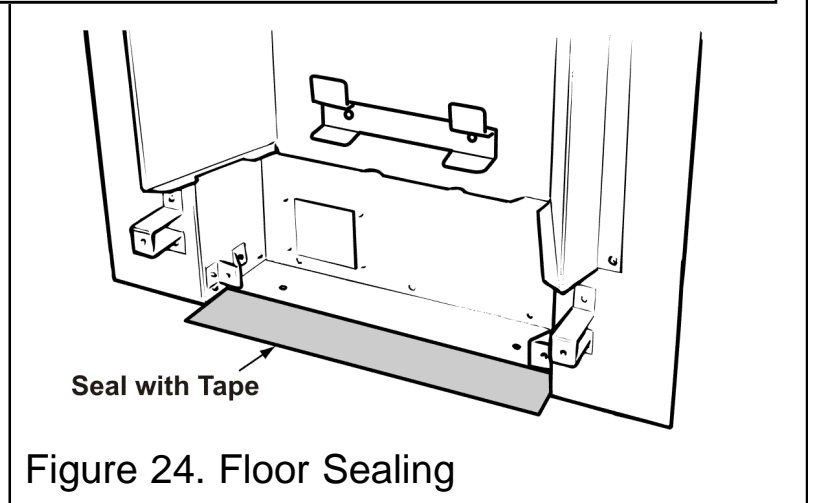

Figure 24. Floor Sealing

INSTALLER GUIDE

9.3 Floor Sealing (All installations)

Using the floor sealing tape supplied, seal the bottom of the convector box to the fireplace and hearth floor. Run the tape over the centre bracket (See figure 24).

10. BURNER & SUPPLY PIPE INSTALLATION

IMPORTANT

Before continuing with the installation of this gas fire the aeration setting on the burner must be checked. The aeration is factory set. See section 17.1 (Servicing and parts replacement).

10.1 Burner & Supply Pipe Installation

1. Refit the burner unit to the convection box with two screws.
2. Reconnect the slider control linkage firmly to the burner control pivot with the shouldered screw using a screwdriver (Not finger tight only).
3. Connect the supply line to the appliance.
4. Pressure check the installation pipework for gas soundness. In the United Kingdom check in accordance with the current edition of BS6891. In the Republic of Ireland refer to the current edition of I.S. 813 “Domestic gas installations”

10.2 Preliminary Burner Checks

Some burner operations can be checked at this stage. Checking now will mean that less disassembly will be required if any problems are found. **A full check should still be made, however, after final installation**

10.2.1 Lighting the burner

1. If closed, open the isolating valve at the inlet ‘T’ connector.
 2. Depress the slider knob as far as it will go and hold in this position (see section 6). This should close the ignition circuit and (now that the gas is connected) simultaneously open the gas tap allowing the gas to flow to the pilot.
- Wait a few seconds while the air is purged. The electronically generated sparks should light the pilot. The pilot should then light the main burner at its low setting. There may be a delay of up to four seconds between the pilot lighting and ignition of the gas at the main burner. This is normal and is due to the time required to fill the main burner compartment with sufficient gas for ignition.

10.2.2 Operating the burner.

1. When the burner is operating properly, gradually slide the control knob upwards. The burner flames should gradually increase until the knob is nearly at its highest position.

INSTALLER GUIDE

You should feel some resistance when the slide button reaches the maximum burner flame position. Sliding further upwards until the knob comes to a stop should then turn the burner and pilot off. When the above checks have been completed close the isolating valve on the inlet 'T' connector. If the above checks are satisfactory, continue with the installation. If not, check the control and ignition circuitry and components as described in the servicing section of this manual.

10.3 Inlet Pressure Check

The appliance is pre-set to give the correct heat input at the inlet pressure shown in section 2 of this manual. No adjustment is necessary.

1. Check the inlet pressure by fitting a pressure gauge at the test point. The test point is on the inlet 'T' connector. See figure 25. Check the pressure with the appliance alight and set at maximum output.
2. After checking, turn off the appliance. Remove the pressure gauge and replace the test point sealing screw.
3. Relight the appliance. Turn to the maximum output position and test around the sealing screw for gas soundness with a suitable leak detection fluid.

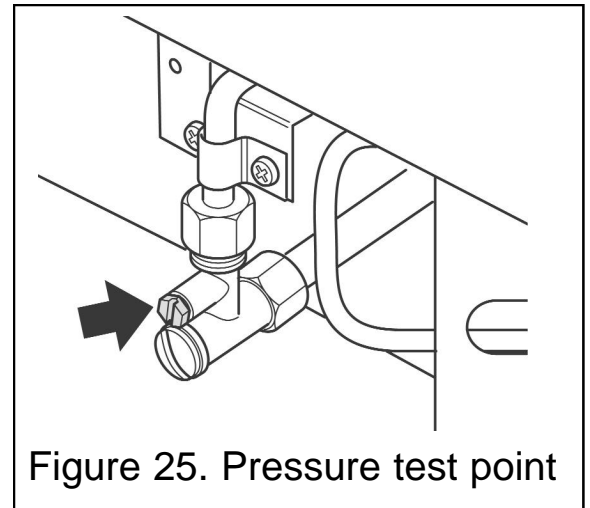

Figure 25. Pressure test point

11. FITTING THE FRONT SURROUND

11.1 Fitting The Front Surround

1. Locate the two lugs at the top of the front surround in the slots in the convection box hood. Swing the bottom of the surround sides back against the convection box and lower the surround so that the lugs are fully seated in the slots in the convection box hood (See figure 26).
2. Refit the two screws to secure the surround sides to the convection box brackets (See figure 27).

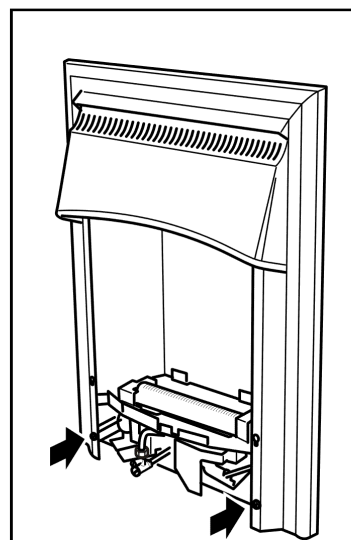

Figure 27. Outer surround side attachment.

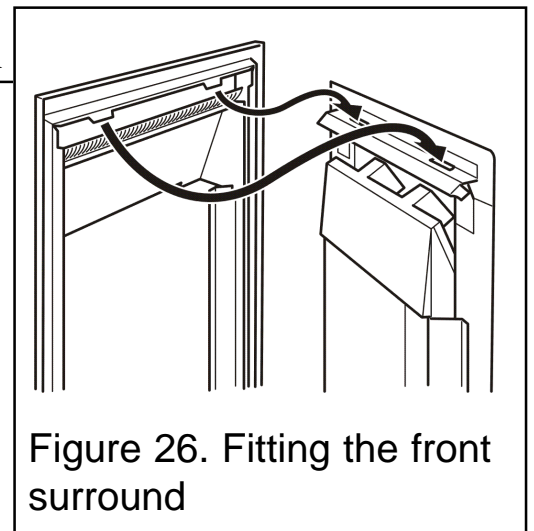

Figure 26. Fitting the front surround

INSTALLER GUIDE

12. CERAMIC COALS INSTALLATION

1. Place the rear base coal in the firebox. It should rest on the ledges at the rear sides of the burner unit. When located gently move the rear base coal so that it is as far forward as possible. The amount of movement will be negligible (See figure 28).

2. Place the front base coal in the firebox with its bottom front locating over the front rim of the firebox. Pull the coal forward so that it locates immediately behind the front rim of the firebox. (See figure 29). The front base coal will touch the rear base coal as it is located.

There are two types of loose coals. These are identified with the letter "A" or "B" on the underside of the coal.

There are three "A" coals and two "B" coals.

3. Place a type "A" coal between the front and rear base coals with the letter "A" upright and so that the coal is against the left side of the firebox. See figure 30.

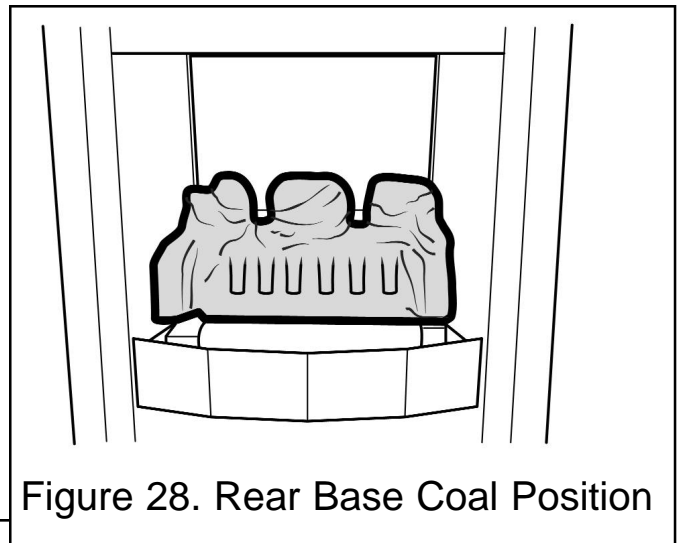

Figure 28. Rear Base Coal Position

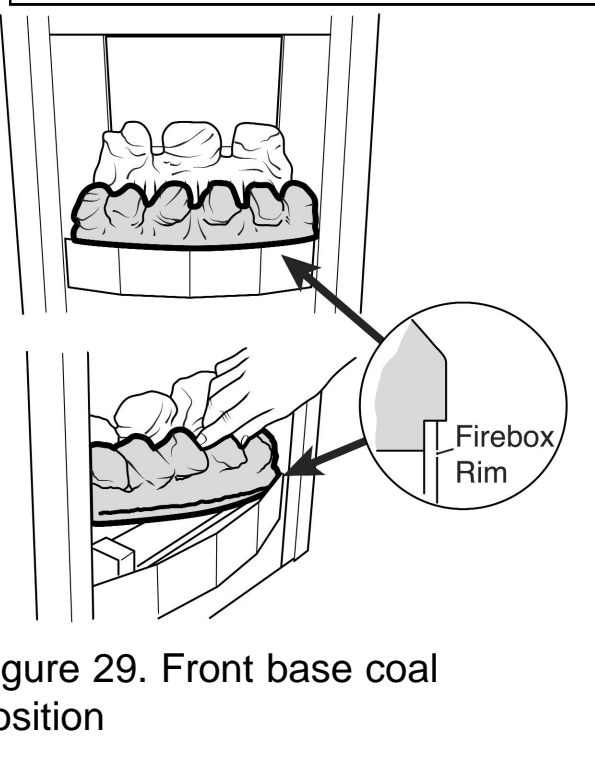

Figure 29. Front base coal position

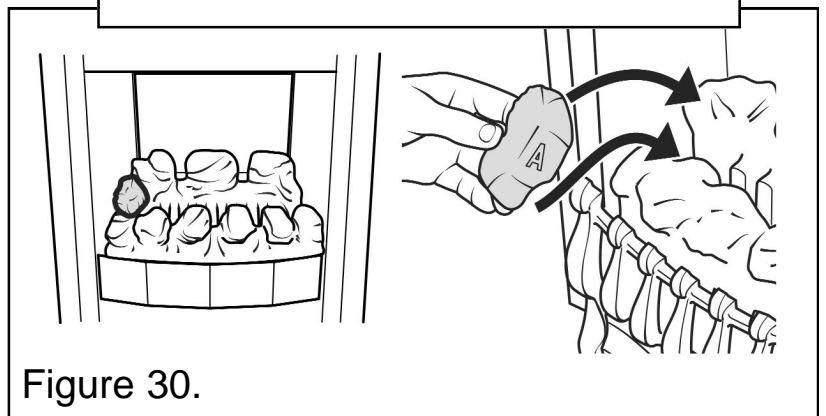
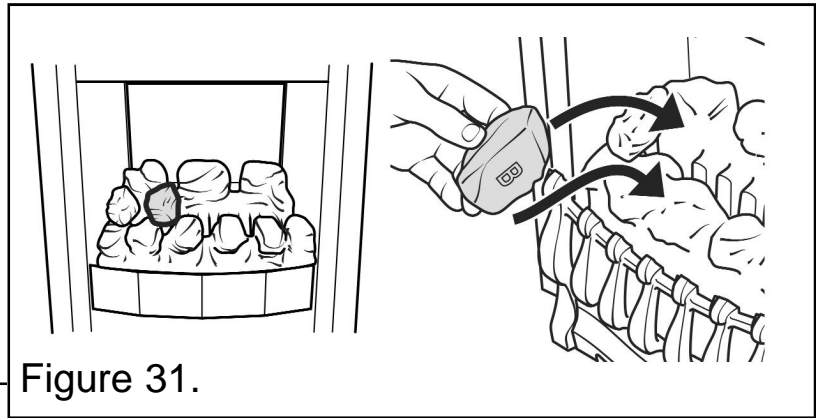

Figure 30.

INSTALLER GUIDE

4. Place a type “B” coal between the front and rear base coals as shown in figure 31. The letter “B” should be upright.



5. Place a type “A” coal between the front and rear base coals with the letter “A” upright. The top of the coal should rest against the centre coal of the rear base coal as shown in figure 32.

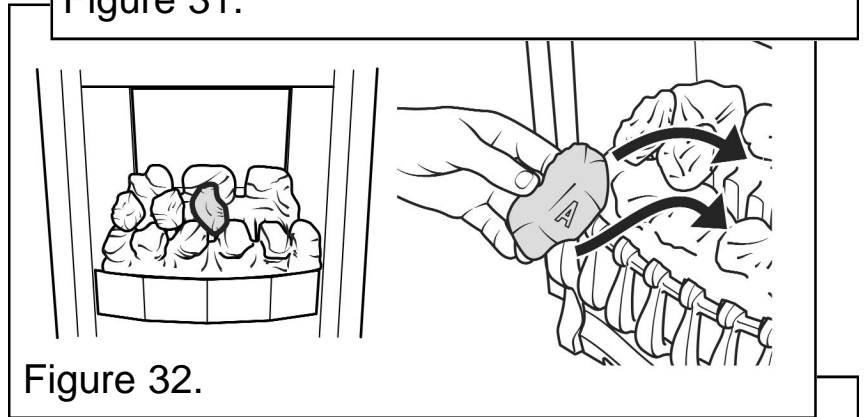

6. Place the remaining type “B” coal at the right side of the firebox between the front and rear base coals. The letter “B” should be upright. The coal should touch the right side of the firebox. See figure 33.



7. Place the remaining type “A” coal between the front and rear base coals. The letter “A” should be upside down with its rear face between the right and centre coals of the rear base coal. Angle the coal so that the gap between it and the type “B” coal to its right is appreciably larger than the gap between it and the type “A” coal to its left but do not have it touching the type “A” coal. This will give the best flame effect. See figure 34



INSTALLER GUIDE

13. FIREFRONT CASTING INSTALLATION

1. Locate the two screw heads through the keyhole slots at the inner sides of the surround. If the screw heads do not project enough or project too far, the screws can be adjusted. Lower the casting so that it rests on the hearth. See figure 35.

3. Fit the front cover casting below the front casting.

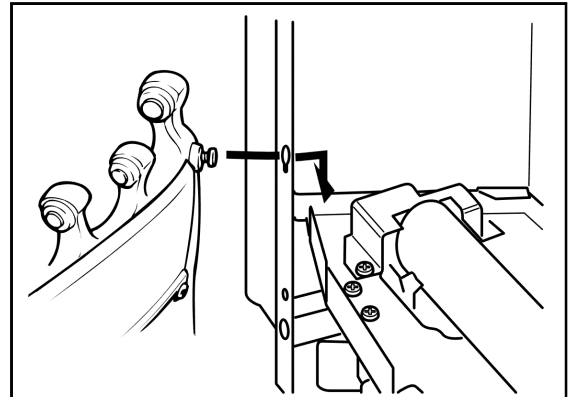

Figure 35. Firefront casting location

14. FULL OPERATING CHECKS

14.1 Recheck the Control Settings

The control position markings on the front surround are shown in figure 36.

Please note:

- When first turned on from cold, the flames will appear predominantly blue.
- When operating the fire for the first time, some vapours may be given off which could set off smoke alarms in the vicinity. These vapours are quite normal with new appliances. They are totally harmless and will disappear after a few hours use.

14.1.1 Lighting the burner

1. Make sure the slider button is at the off position (At topmost position marked "O" on the front surround).

2. Open the isolating valve on the inlet 'T' connector

3. Slide the button to the bottom (ignition) position marked . Retain in this position to ignite the pilot. The burner should ignite at its lowest setting within 4 seconds of the pilot igniting. Keep at this position for a further 10 seconds to allow the pilot flame to stabilise.

4. Release the button. The button should automatically spring up to the low heat position. If the flames go out at this stage or when checking the rest of the setting positions, try the full lighting sequence again. If the flames fail after two attempts,

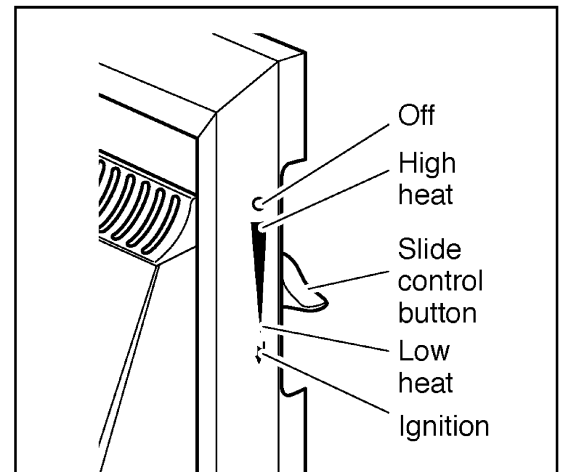

Figure 36. Control position markings

INSTALLER GUIDE

investigate the pilot unit.

14.1.2 Operating the burner.

1. Gradually slide the button up to increase the burner setting. The burner should be at its maximum setting at the high heat position shown in figure 36. You should feel a check to the button movement at this position.
2. Slide the control button up past the high heat position to the off ("O") position at the top of the slide slot. Both pilot and main burner should go out. While cooling the coals may make some crackling noises. This is quite normal.
3. Check that the control linkage bar does not interfere with the appliance cable retention nuts or wires.

15. SPILLAGE & FLAME SUPERVISION CHECKS

15.1 Check for Spillage

A spillage check must be made before leaving the installed appliance with the customer. Make this with all the ceramic fuel effect pieces in position.

1. Close all doors and windows in the room containing the appliance.
2. Light the appliance and lift the slider knob to "HIGH".
3. Leave the appliance on for five minutes.
4. Place the smoke match tube into the convection box at the right hand side and immediately below the black top cross member. Angle it at approximately 45° to the horizontal.

Insert the tube so that the neck of its flared end touches the inside surface of the edge of the cross member - See figure 37.

Keeping the neck of flared end in contact with the edge of the cross member, slide the tube to the left until you feel it enter the notch in the edge of the cross member.

Make sure that the tube is pointed upwards at 45° to the horizontal. The installation is satisfactory if the smoke is drawn into the appliance. If the smoke is not drawn into the appliance leave the appliance alight at the maximum setting for a further ten minutes and then repeat the test. If the smoke is still not drawn into the appliance inspect the sealing to

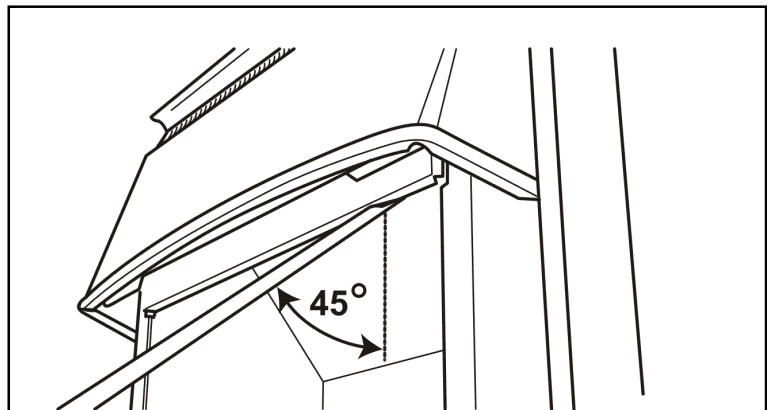

Figure 37. Spillage check

INSTALLER GUIDE

the fireplace surround. If the sealing is satisfactory but the appliance is installed with the flue restrictor (see section 8.2) remove the restrictor, reseal the appliance and retest. If smoke is still not drawn into the appliance disconnect the appliance and seek expert advice.

5. If the above test is satisfactory open all internal connecting doors, hatches, etc. in the room. Keep all doors and windows that open to the outside of the building closed. Recheck for spillage as above. If an extractor fan is installed in the same room as the appliance or a connecting room, check that spillage does not occur with the fan operating and all doors and other openings between the fan and the appliance open. If the smoke is drawn into the appliance, continue with the installation. **If the test is not satisfactory disconnect the appliance and advise the customer of the cause of failure.**

15.2 Flame Supervision & Spillage Monitoring System

This pilot unit includes a system that will automatically shut off the gas supply if the pilot flame goes out or if there is insufficient oxygen due to spillage or poor ventilation. Check that the system operates properly as follows;

1. Light the appliance. Set the slide control to the maximum burning position and leave for one minute.
2. Set the control to the Low burning position. Isolate the gas supply at the inlet elbow. The pilot and main burner will go out. Note the time when the pilot goes out. Listen for a snap sound at the gas tap. Note the time when the sound is heard. This sound is caused by an electromagnetic valve shutting off the gas supply through the tap. The valve is located in the body of the tap. The valve should operate within 60 seconds of the pilot going out. If the valve does not operate within this time limit do not allow the appliance to be used until the fault has been corrected.

This monitoring system must not be adjusted, bypassed or put out of operation.

This monitoring system, or any of its parts, must only be exchanged using authorised parts.

3. Open the isolating valve on the inlet elbow. Screw on the end cap and test for leaks. Set the slider to the "Off" position.

This monitoring system must not be adjusted, bypassed or put out of operation.

This monitoring system, or any of its parts, must only be exchanged using authorised parts.

INSTALLER GUIDE

16. FINAL REVIEW

1. Visually inspect the appliance. Clean off any marks incurred during installation.
2. Advise the customer how to operate the fire.
3. Explain to the customer that the appliance has a flame failure and spillage monitoring system. Point out the explanation of this system shown in the owner's guide. Advise that if the fire goes out for any reason, wait at least three minutes before relighting. Stress that if the monitoring system repeatedly shuts off the fire, the appliance should be switched off and a specialist should be consulted. Point out that the lighting instruction details are on a metal plate attached at the bottom of the appliance.
4. Advise that the fire may give off a slight odour while new. This is quite normal and it will disappear after a short period of use.
5. Advise that any cleaning must only be carried out when the fire is off and cold.
6. Advise the customer that they should read the Owner's guide before operating the fire and always follow the advice in the section headed "Cleaning".
7. Advise the customer that the appliance will operate to its maximum potential if the flue is primed during the first 20 – 30 minutes of use. To do this, simply turn the control to its highest setting. This will also burn off any carbon deposits that may have formed during previous use.
If using the appliance for long periods it is beneficial to change between settings. This will also help to remove any carbon deposits that may form during use.
8. Recommend that the appliance should be serviced and the chimney inspected by a competent person (In the UK a CORGI registered person) at least annually.
If the appliance is in premises in the United Kingdom occupied by a tenant, point out that by law a landlord must have any gas appliance, flue and pipework which is situated in a tenant's premises checked for safety at least every 12 months.
9. Advise the customer that the castings, front surround, firebox and ceramic pieces can be cleaned as described in the user's instructions and that the loose ceramic fuel effect pieces must be replaced as described in those instructions.
Stress that no extra coals must be added over and above those supplied with the appliance and that any replacements must only be the authorised spares. Warn that ignoring this advice could cause incomplete clearance of the products of combustion with consequent health hazards.
10. **Inform the customer that the Serial number for the appliance is located on the metal plate, located behind the lower front casting and underneath the burner.**
11. Hand the literature pack with this guide to the customer.

17. SERVICING & PARTS REPLACEMENT

Always turn off the gas supply before commencing any servicing (The appliance inlet “T” connector incorporates an isolating valve).

It is recommended that, at least once a year, the appliance is disconnected and the fireplace opening checked and cleared of any debris.

This product uses fuel effect pieces and a burner compartment rear wall containing Refractory Ceramic Fibres (RCF), which are man-made vitreous silicate fibres. Excessive exposure to these materials may cause irritation to eyes, skin and respiratory tract. Consequently, it is important to take care when handling these articles to ensure that the release of dust is kept to a minimum. To ensure that the release of fibres from these RCF articles is kept to a minimum, during installation and servicing we recommend that you use a HEPA filtered vacuum to remove any dust and soot accumulated in and around the fire before and after working on the fire. When replacing these articles we recommend that the replaced items are not broken up, but are sealed within a heavy duty polythene bag, clearly labelled as RCF waste. This is not classified as “hazardous waste” and may be disposed of at a tipping site licensed for the disposal of industrial waste. Protective clothing is not required when handling these articles, but we recommend you follow the normal hygiene rules of not smoking, eating or drinking in the work area and always wash your hands before eating or drinking.

- Check that the appliance is clean and that soot or debris is not blocking the gaps between the coals causing an imperfect flame.
- Check that soot or debris is not impairing the electrode spark or pilot burner.
- Check that soot or debris is not blocking any of the holes in the main burner.
- After servicing, make sure that the ceramic rear wall and coals are replaced correctly as described in the installation instructions.
- **Always test for gas soundness and spillage after servicing the appliance.**

17.1 Checking the aeration setting of the burner.

1. The aeration collar is factory set and **will** require adjustment. **It is important to ensure that the aeration setting is correct (See figure 38).**

2. To adjust the aeration setting, loosen the two aeration shutter screws, slide the aeration shutter to the position shown in figure 38 and tighten the fixing screws.

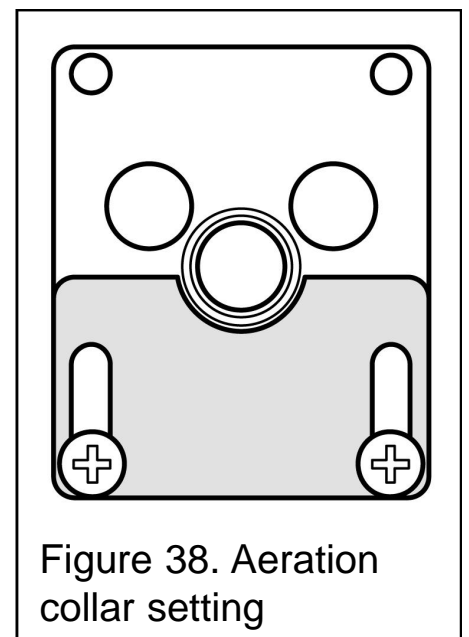

Figure 38. Aeration collar setting

INSTALLER GUIDE

17.2 To Remove the Ignition Microswitch

See figures 39 & 40

The ignition microswitch is stamped V4NT9C4YC

1. Remove the bottom front cover and the front cover casting.
2. Detach the microswitch cover by removing one screw and pulling clear of the location lug. See figure 39.
3. Disconnect the leads from the ignition microswitch (The lower of the two microswitches - See figure 40).
4. Detach the microswitch and insulation pad by removing two screws.
5. Replace in the reverse order.
6. Check that the microswitch operates correctly by fully closing it and observing that there are sparks at the pilot electrode.

17.3 To Remove the Gas Shut-Off Microswitch

See figures 39, 40 & 41.

The gas shut-off microswitch is stamped V4NT9C2YCGPX or V4NT9C2YCAUX.

1. Remove the bottom front cover and the fire front casting.
2. Detach the microswitch cover by removing one screw and pulling clear of the location lug. See figure 39.
3. Loosen the thermocouple nut to free the microswitch leads and pull the leads clear of the thermocouple interrupter block. See figure 41.
4. Detach the bridging bracket, microswitch assembly by removing two screws. See figure 40.

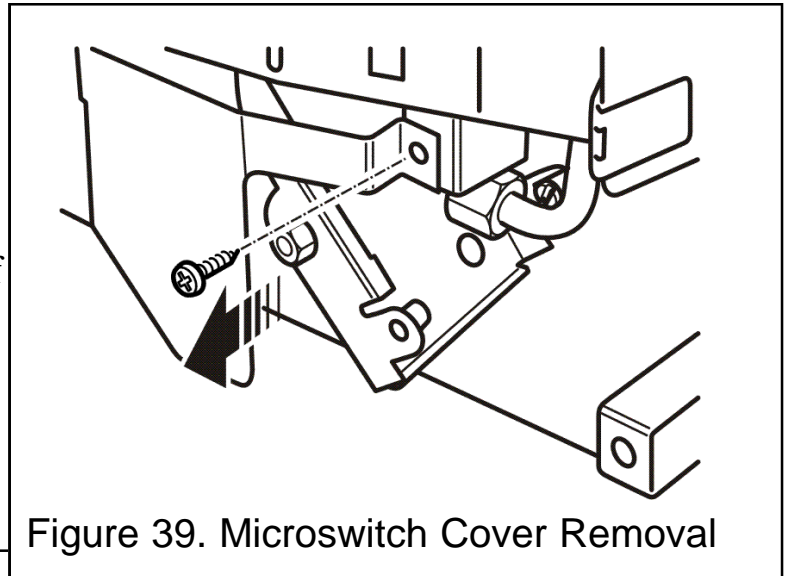

Figure 39. Microswitch Cover Removal

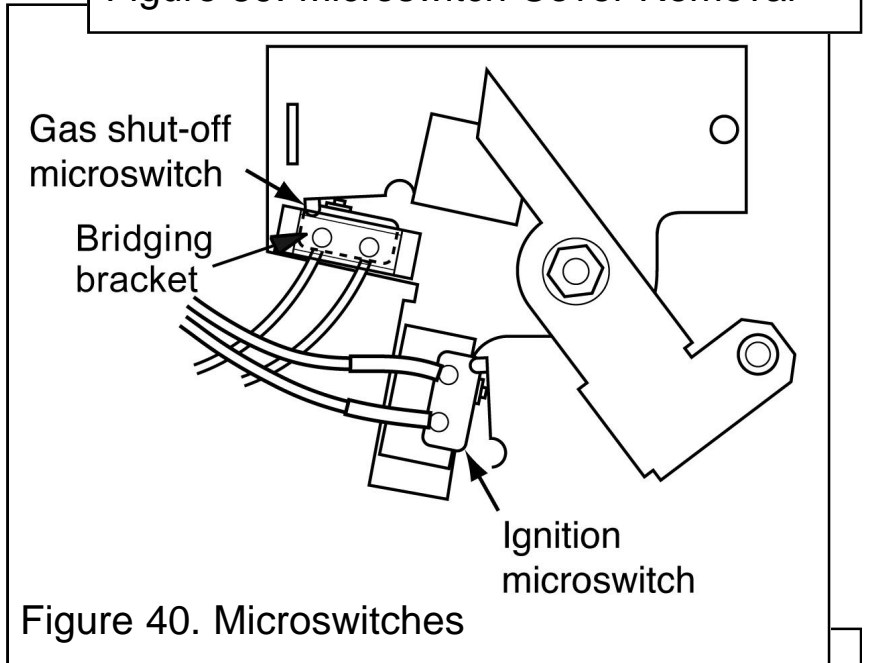

Figure 40. Microswitches

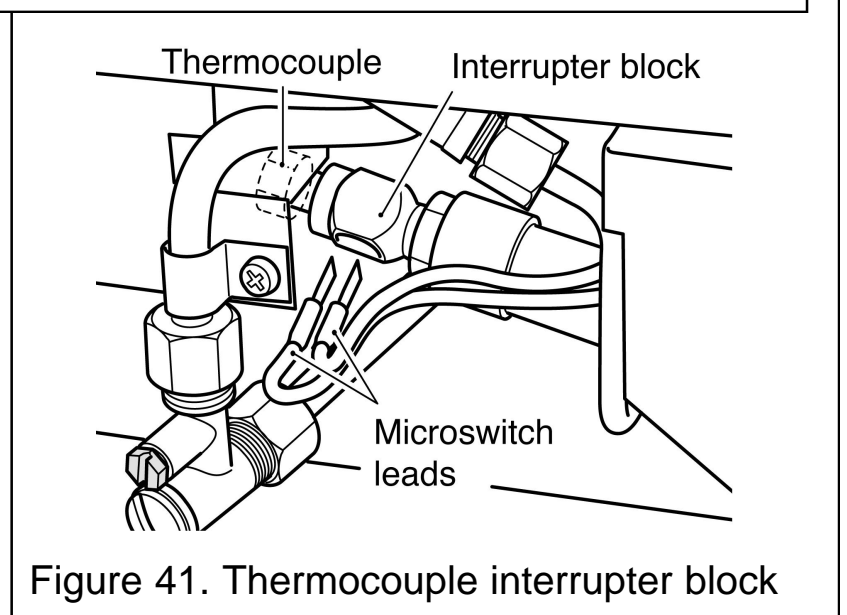

Figure 41. Thermocouple interrupter block

INSTALLER GUIDE

5. Replace in the reverse order. When refitting the leads to the interrupter block, make sure that they are secured firmly to give a good electrical contact.

17.4 To Remove the Fire Front Surround

1. Remove the bottom front cover and the fire front casting.
2. Detach the control-linking bar from the control pivot bracket by removing the knurled screw, which joins the control linking bar to the control pivot unit. See figure 42.
3. Remove the two screws securing the bottom of the front surround to the sides of the convection box. See figure 43.
4. **Make sure that the control linking bar has been detached (See point 2).** Carefully lift the surround unit upward to clear the upper retaining brackets on the convection box - See figure 44. Pull the surround clear and place carefully aside.
5. Refit in the reverse order. Make sure that the surround is properly located over the upper retaining brackets. See section 11 of this manual for detailed fitting instructions.

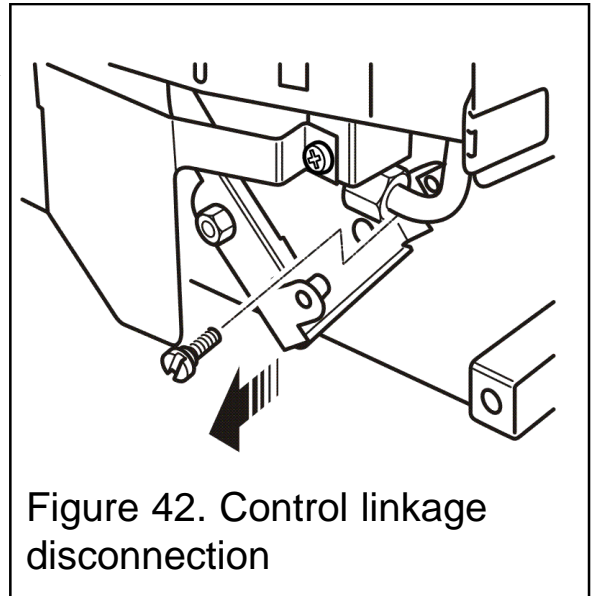

Figure 42. Control linkage disconnection

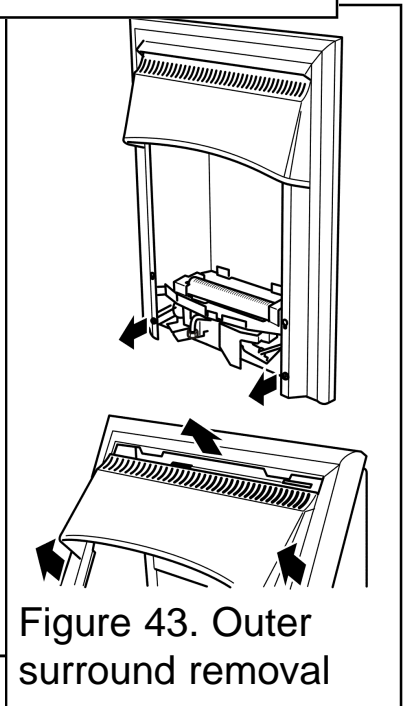

Figure 43. Outer surround removal

17.5 To Replace the Control Slide Button

1. Remove the front surround - See section 17.4
2. Detach the slide button by removing two screws – See figure 44.
4. Replace in the reverse order.

17.6 To Remove the Burner Unit

1. Remove the front surround - See section 17.4.
2. Remove the loose ceramic fuel effect pieces, the front ceramic fuel effect and the base ceramic fuel effect.
3. Support the inlet 'T' connector to avoid straining the pipework and disconnect the appliance from the 'T' connector.
4. Detach the burner unit from the convection box by removing two screws

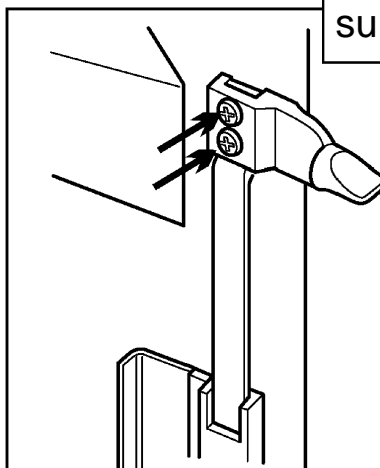

Figure 44. Front Surround Bottom location (Shown with Ultimate slide button)

INSTALLER GUIDE

–See figure 45.

5. Replace in the reverse order.

17.7 To Remove the Electronic Ignition Generator

1. Remove the burner unit - See section 17.6
2. Remove the battery.
3. Remove the spark lead and microswitch leads remembering to make note of their positions.
5. Unscrew the two fixing screws that attach the generator unit to the support bracket. The igniter generator can now be removed. (see figure 46)
8. Replace the generator
9. Refit in the reverse order.

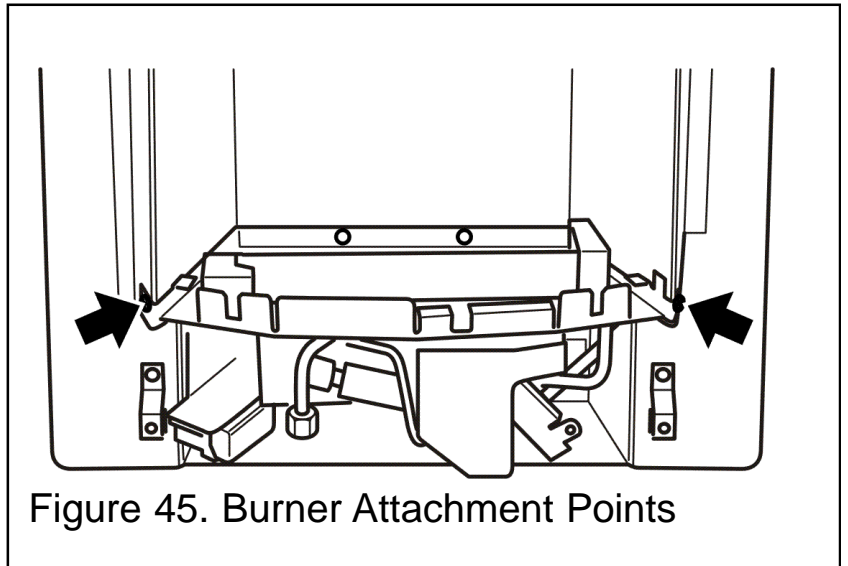

Figure 45. Burner Attachment Points

17.8 To Remove the Thermocouple Interrupter Block

See figure 47.

1. Remove the burner unit - See section 17.6.
2. Detach the thermocouple from the interrupter block by unscrewing the thermocouple nut.
3. Detach the two microswitch leads from the interrupter block.
4. Remove the interrupter block by unscrewing from the gas shut-off tap.
5. Refit in the reverse order. If the microswitch leads cannot be easily attached to the interrupter block when it is fully tightened to the gas shut-off tap, slacken it and rotate to allow the leads to be fitted. Retighten making sure that the leads remain in place in the interrupter block. Fit and tighten the thermocouple nut making sure that the leads are secured in the

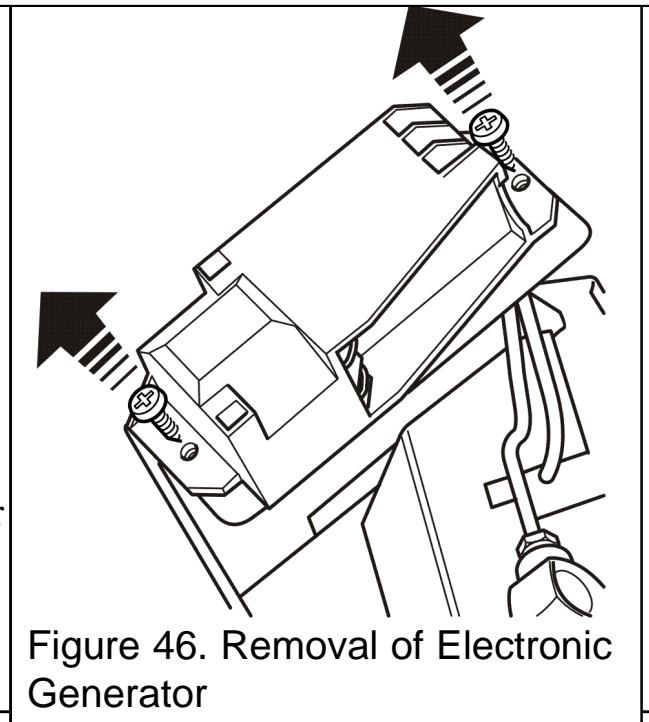

Figure 46. Removal of Electronic Generator

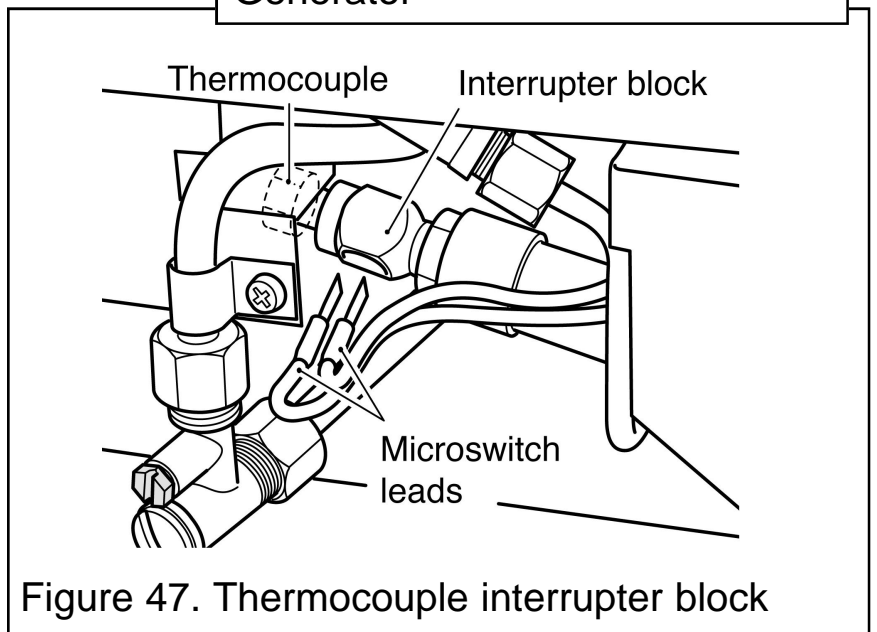

Figure 47. Thermocouple interrupter block

INSTALLER GUIDE

interrupter block to give a good electrical contact.

17.9 To Remove the Pilot Unit

1. Remove the burner unit - See section 17.6.
2. Detach the pilot pipe from the pilot unit.
3. Detach the thermocouple from the interrupter block by unscrewing the thermocouple nut.
4. Detach the electrode lead from the underside of the electrode tab.
6. Remove the two screws securing the pilot unit. See figure 48.
7. Refit in the reverse order.

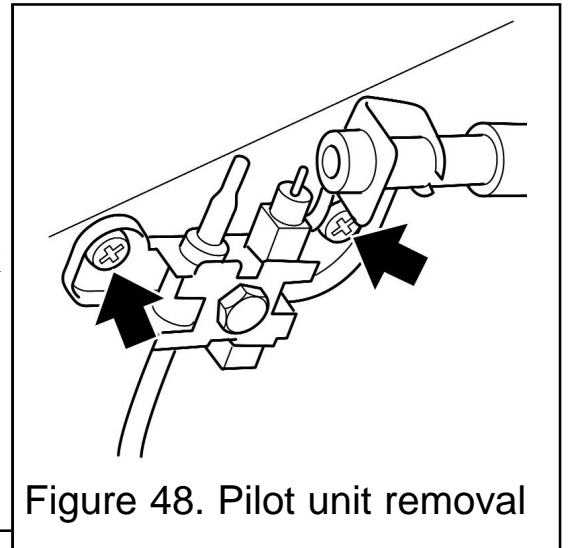

Figure 48. Pilot unit removal

Note:

1. *The pilot unit is an atmosphere sensing device. It must be replaced as a whole assembly. Its individual components are not separately replaceable.*
2. *When the thermocouple is removed from the interrupter block, the microswitch lead terminals in the interrupter block will be loose. Make sure that they are properly secured to give a good electrical contact when retightening the thermocouple nut.*

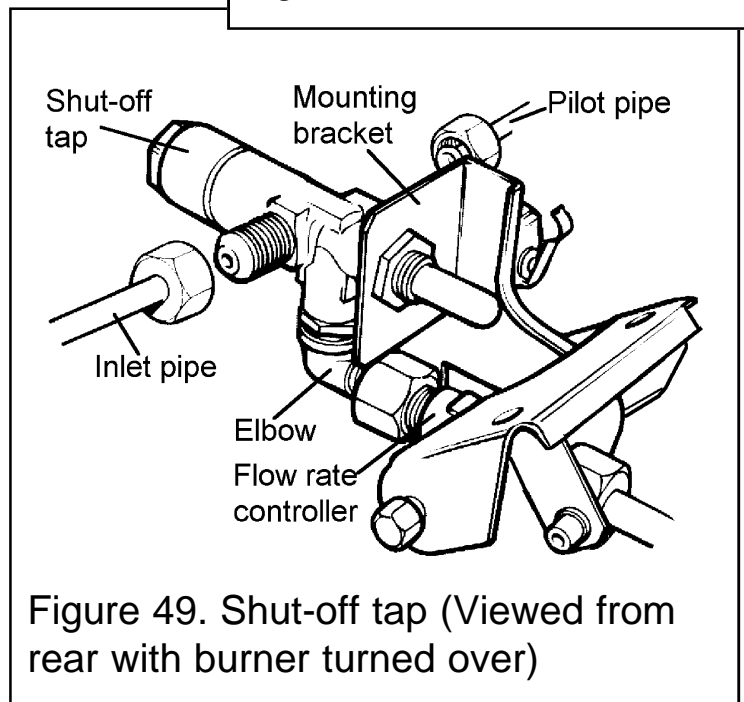

Figure 49. Shut-off tap (Viewed from rear with burner turned over)

17.10 To Remove the Shut-Off Tap

See figure 49.

1. Remove the burner unit - See section 17.6.
2. Turn the burner unit upside down. Detach the thermocouple and interrupter block from the tap - See section 17.8 paragraphs 2 - 4.
3. Detach the pilot pipe from the tap.
4. Detach the inlet pipe.
5. Remove the hexagonal nut securing the tap to the mounting bracket.
6. Detach the elbow by unfastening the hexagonal nut connecting it to the flow rate controller. Lift the tap (complete with elbow) clear.

INSTALLER GUIDE

7. Loosen the hexagonal locknut securing the elbow to the tap. Remove the elbow by rotating it.
8. If fitting a new tap, remove the hexagonal nut at the mounting bracket end of the old tap and fit to the replacement tap. Prior to refitting the elbow to the shut-off tap, apply an approved sealant to the elbow thread. Refit in the reverse order.

Refer to figure 50 to ensure accurate refitting dimensions of the valves and subsequently into the

mounting bracket. When refitting, make sure that the tap spindle is in the correct relationship relative to the control pivot bracket. Rotate the pivot bracket fully clockwise. The tap spindle should "bottom out" (i.e. the tap should be fully open) after the pivot bracket has actuated the ignition microswitch but before it has pushed the microswitch leaf against the microswitch body.

When refitting the thermocouple and interrupter block, make sure that the microswitch wires are properly secured to give a good electrical contact.

17.11 To Remove the Gas Flow Rate Controller

See figure 51.

1. Remove the burner unit - See section 17.6.
2. If lying the burner on its back, ensure that the worksurface is suitably protected. This will avoid damage to the worksurface.
3. Detach the microswitch cover - See section 17.2 paragraph 2.
4. Detach the shut-off tap as detailed in section 17.10 paragraphs 2-6.
5. Detach the burner pipe from the controller. Support the controller while detaching to prevent excessive strain.
6. Remove the nut and washer securing the control pivot bracket to the controller at the front. Support the pivot bracket while removing the nut to prevent possible damage to

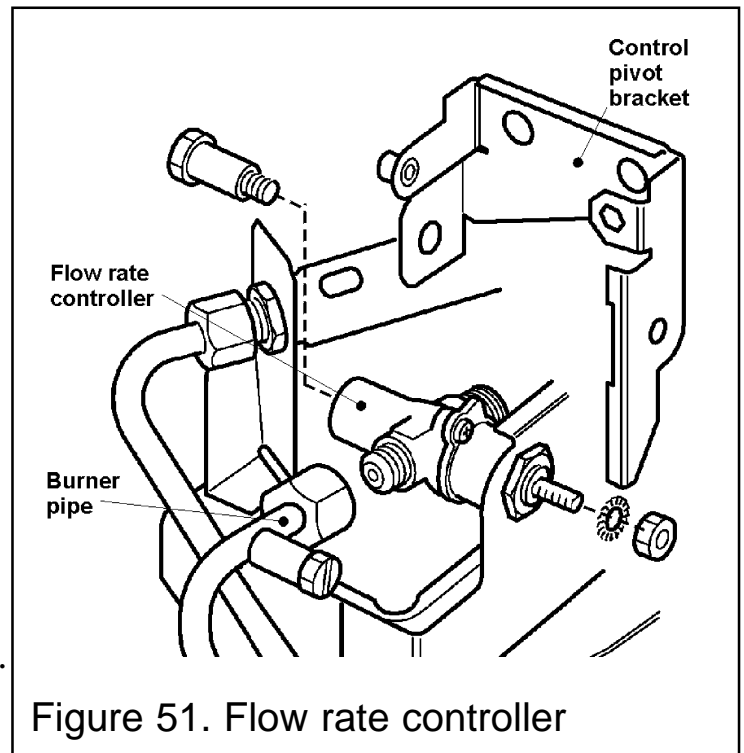
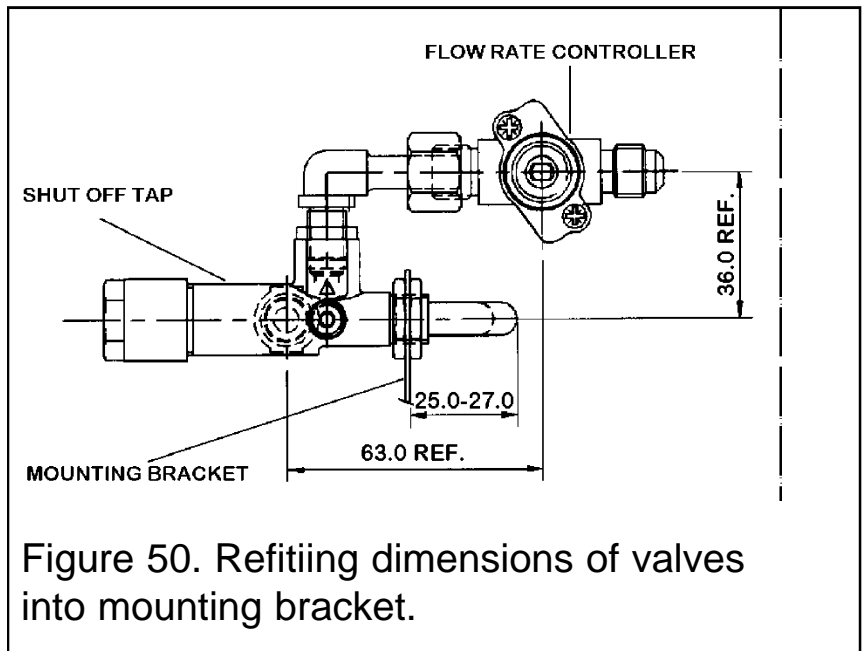

INSTALLER GUIDE

the microswitch.

7. Remove the hexagonal bolt securing the control pivot bracket to the controller at the rear.
8. Detach the control pivot bracket.
9. Remove the hexagonal nut securing the controller to the front mounting bracket and remove the flow rate controller.
10. Refit in the reverse order.

17.12 To Replace the Burner

See figure 52.

1. Remove the burner unit - See section 17.6.
2. Support the elbow injector and unscrew the injector nut.
3. Remove the two screws from the burner clamping plate (See figure 52)
4. Lift the right hand side of the burner, slide it to the right and lift clear
5. Refit in reverse order.

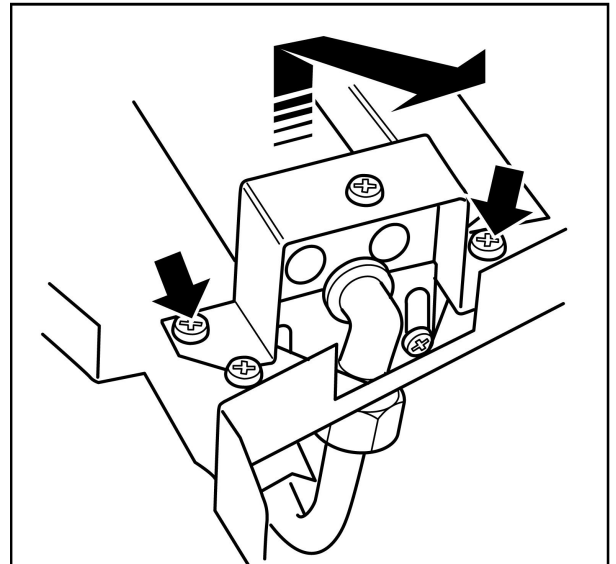

Figure 52. Removal of burner

17.13 To Remove the Main Burner Injector

See figure 53.

1. Remove the burner - See section 17.12.
2. Remove the burner clamping screw (See figure 53)
3. Unscrew the injector from the burner
4. Refit in the reverse order.

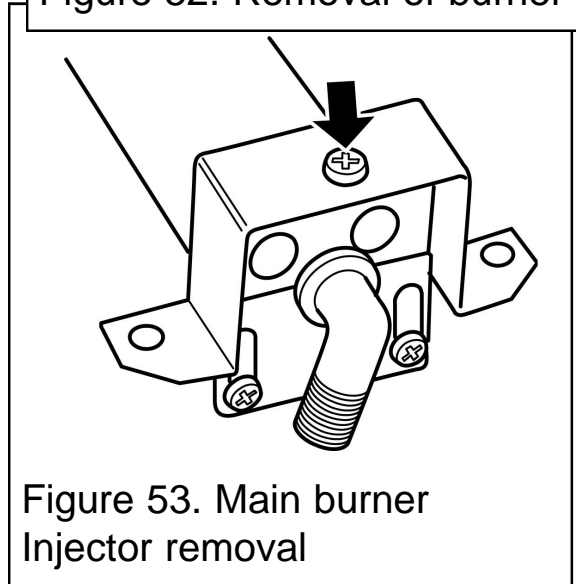

Figure 53. Main burner injector removal

17.14 To Remove the Appliance from the Fireplace

1. Remove the burner unit - See section 17.6.
2. If the fire retention is as method 1 (See section 9.1 of installation instructions), remove the screws.
If the fire retention is as method 2 (See section 9.2 of installation instructions), slacken the hexagonal adjusters on the cable retainers and unscrew the thumbscrews to release the cables.
3. Refit as described in the relevant installation sections. Make sure gas soundness, sealing, spillage test and performance are satisfactory.

INSTALLER GUIDE

INSTALLER GUIDE

18. SHORT LIST OF SPARES

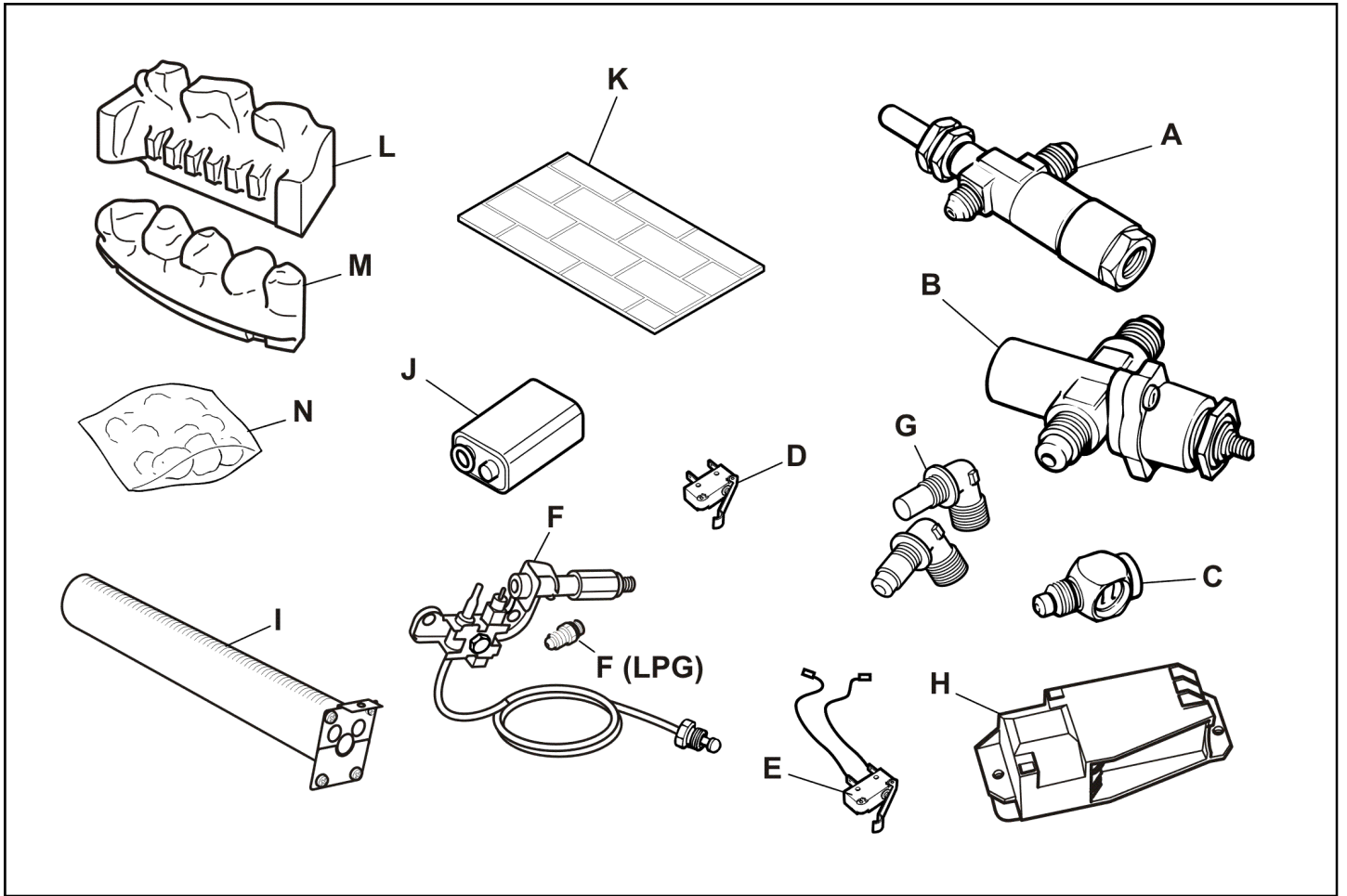

INSTALLER GUIDE

KEY NO.	DESCRIPTION	NO. OFF	MAKER'S PART NO.
A	Shut-off tap	1	0540899
B	Gas flow rate controller	1	0540919
C	Thermocouple interrupter block	1	5108851
D	Ignition microswitch	1	0540959
E	Gas shut-off microswitch	1	0540969
F	Pilot unit - <i>For Natural Gas Appliances</i>	1	3002988
	Pilot injector - <i>For Propane Gas Appliances</i>		5108552
G	Injector Stereomatic Cat 82 - 074 - <i>For Natural Gas Appliances</i>	1	5108136
	Injector Stereomatic Size 132 and carrier - <i>For Propane Gas Appliances</i>		5108558
H	Igniter unit	1	0554949
I	Burner - For Natural Gas	1	5108621
	Burner - For Propane Gas		5109353
J	Battery 9V Size "PP3"	1	0553389
K	Back wall	1	0579339
L	Rear coal base	1	5108542
M	Front coal base	1	5108541
N	Pack of loose coals	1	0582839